

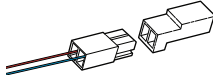

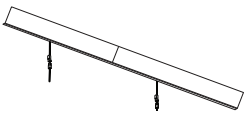

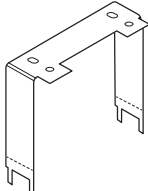

## INSTALLATION INSTRUCTIONS

### LED REPLACEMENT KIT (ONLY FOR FIXTURES SHIPPED PRIOR TO DECEMBER 2024)

PART	PART NO.	DESCRIPTION
<b>QUICK CONNECTS:</b>		
	100-00149-09	Static White 18AWG to 22AWG
	—	Replacement LED Reflector with 3 Leads
	164564	Universal Bracket For BPRO-LIN - USE BRACKET AS PROVIDED. For BPRO-REC or BPRO-PER, break off tabs on both legs of bracket before installing.
	100-00199-09	3 Conductor WAGO Compact
	100-00018-14	#6-32 x 3/16" Phillips Drive Pan Head Zinc Finish Steel Thread Rolling Screw
	100-00486-10	Seam Reflector

**WARNING:** Ground fixture in accordance with local and national electrical codes. Failure to do so may result in serious personal injury. Fixture Installations should ONLY be done by a qualified licensed electrical professional.



## INSTALLATION INSTRUCTIONS

### LED REPLACEMENT KIT (ONLY FOR FIXTURES SHIPPED PRIOR TO DECEMBER 2024)

- 1)** Remove defective LED reflector from fixture.

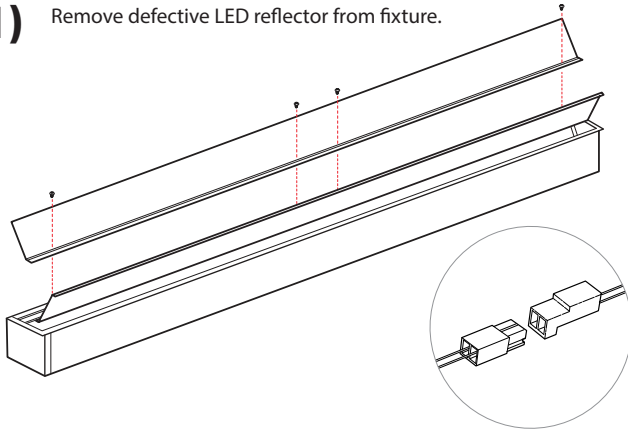

- 2)** 5' & below have same size replacements.  
8' / 7' / 6' LED reflectors will be replaced with two LED reflectors (4' + 4' / 4' + 3' / 3' + 3' respectively).

Make sure to identify where the absent stiffener location is as this will be an installation location for a bracket that will support both reflectors.

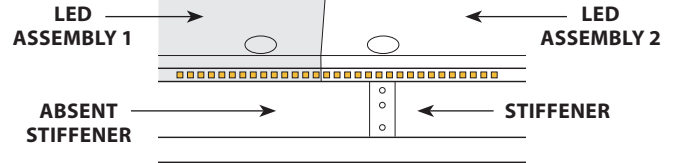

**FOR LINEAR FIXTURES SKIP TO STEP 5**

- 3)** Slide bracket supplied with kit underneath existing stiffener. Align slot and hole on bracket with holes on stiffener as shown below

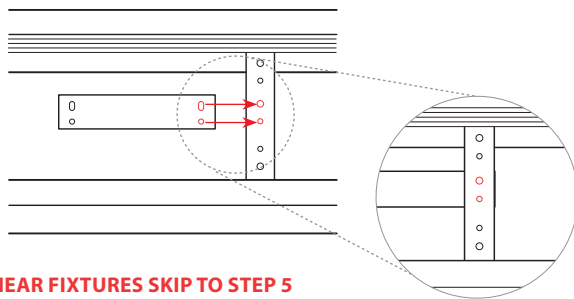

**FOR LINEAR FIXTURES SKIP TO STEP 5**

- 4)** Install 6-32 screw through stiffener hole into bracket slot to attach bracket as shown below.

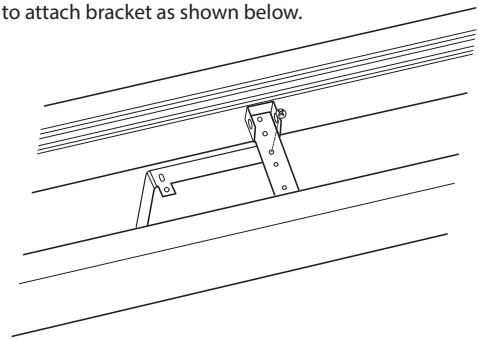

**FOR LINEAR FIXTURES SKIP TO STEP 5**

- 5)** Two replacement LED assemblies will now need to be wired in parallel. Connect wiring and wiring harnesses to line coming from fixture to split LED power into two sections allowing power to each LED assembly.

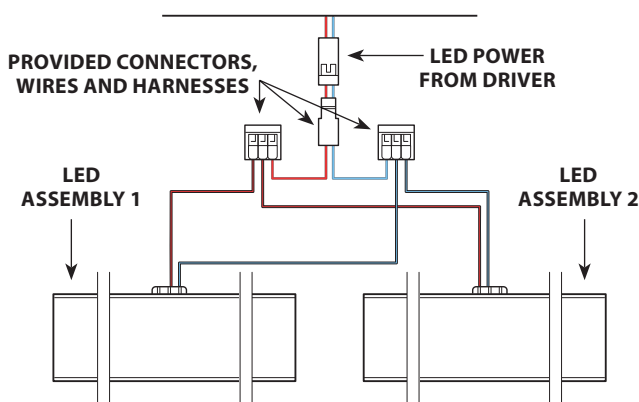

- 6)** Attach wire harness to LED assemblies and reinstall as shown below.

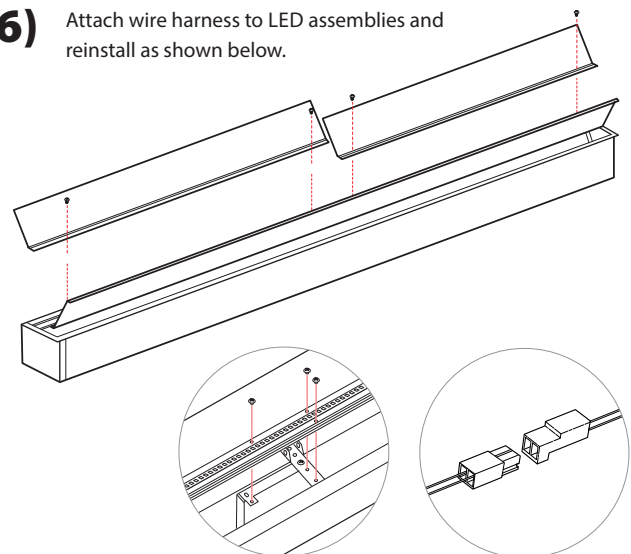

**WARNING:** Ground fixture in accordance with local and national electrical codes. Failure to do so may result in serious personal injury. Fixture Installations should ONLY be done by a qualified licensed electrical professional.



## INSTALLATION INSTRUCTIONS

### LED REPLACEMENT KIT (ONLY FOR FIXTURES SHIPPED PRIOR TO DECEMBER 2024)

**7a)** Tear seam reflector at perforation.  
Peel film to reveal adhesive.

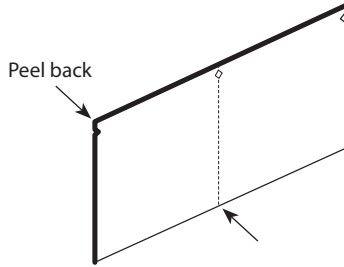

**7b)** Insert seam reflector under brake.

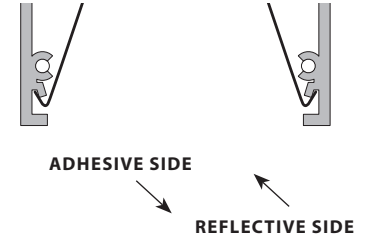
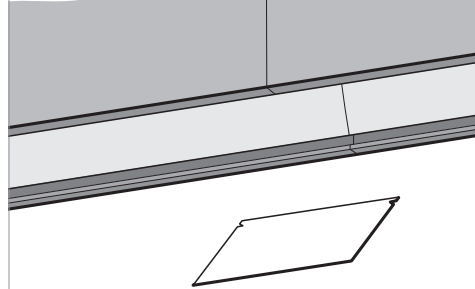

**7c)** Secure the seam reflector.

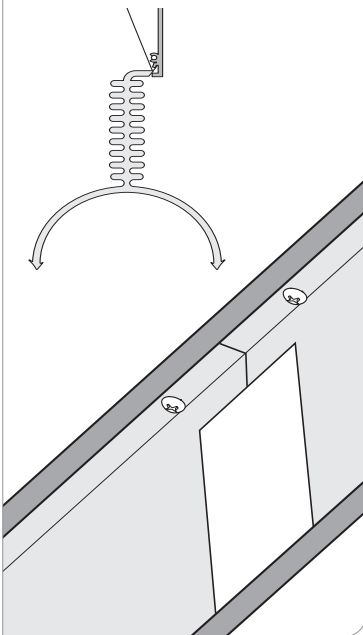

**8)** Reinstall lens.

**WARNING:** Ground fixture in accordance with local and national electrical codes. Failure to do so may result in serious personal injury.  
Fixture Installations should ONLY be done by a qualified licensed electrical professional.