

Stream2 | Recessed Linear X1, X2, X6 (Grid Ceiling)

INSTALLATION INSTRUCTIONS



PRUDENTIAL LTG.

PRULITE.COM 213.746.0360

PARTS (SHIPPED SEPARATELY)

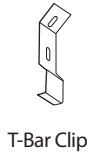

T-Bar Clip



#8 x 3/8" Sheet Metal Screw



8-32 x 2" Machine Bolt



8-32 U-Nut



Aligner Spline

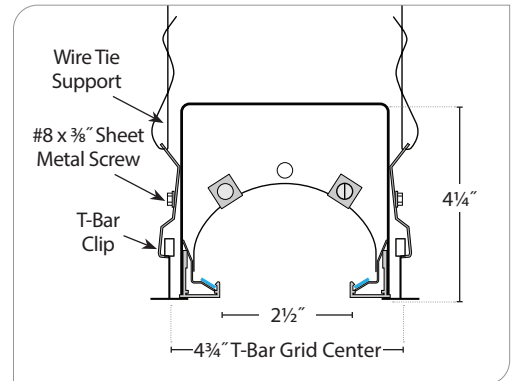

GENERAL NOTES

Length of housing/rows is equal to ceiling grid centers.
Start/end housing are notched on one end to compensate for top of grid.

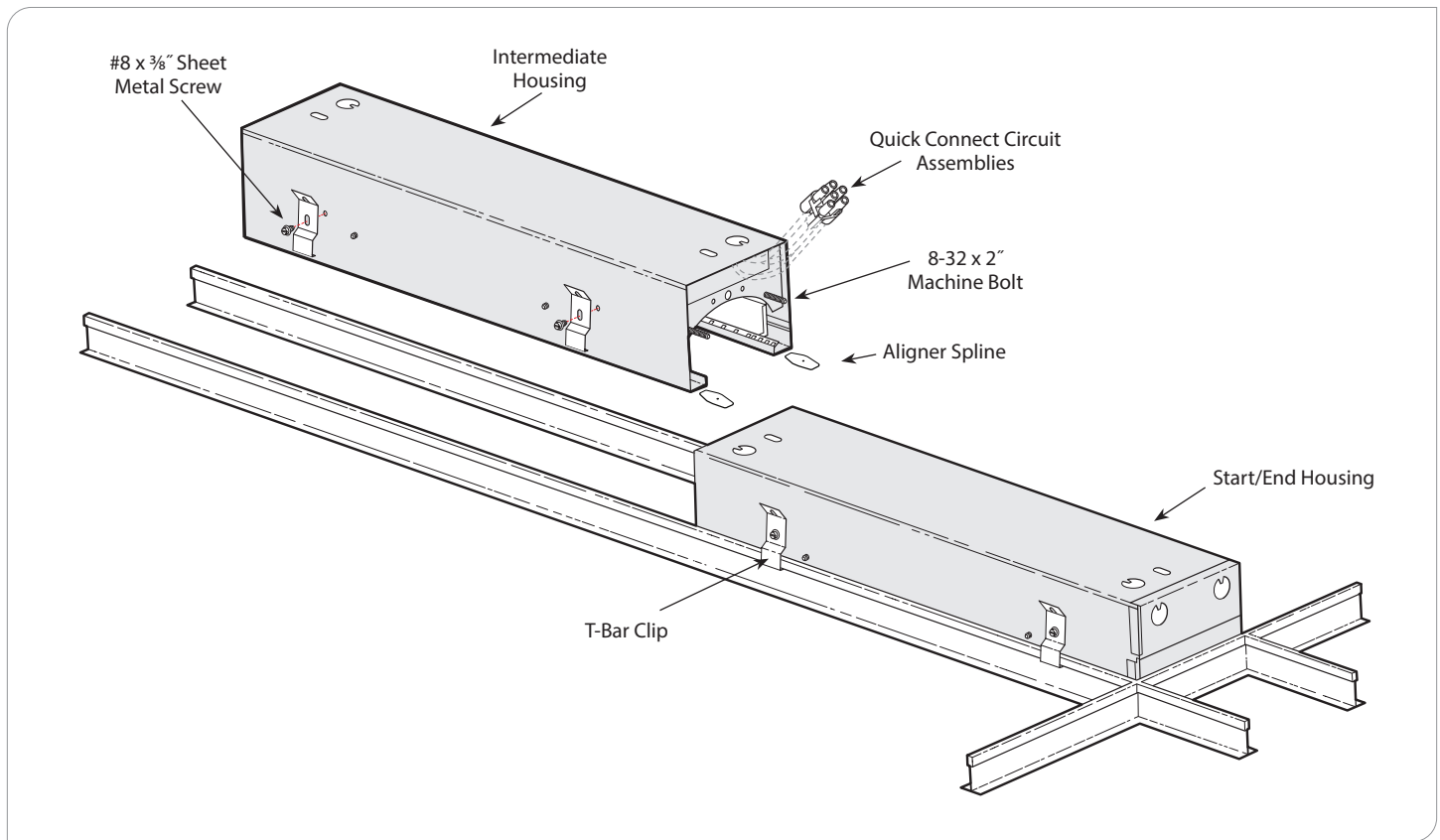

WARNING: Ground fixture in accordance with local and national electrical codes. Failure to do so may result in serious personal injury.
Fixture Installations should ONLY be done by a qualified licensed electrical professional.

Stream2 | Recessed Linear Filler Kit

INSTALLATION INSTRUCTIONS



PRUDENTIAL LTG.

PRULITE.COM 213.746.0360

NOTES

- See row diagram or Prudential Lighting plan layout (if provided). Begin all row mounting from left to right (see arrows).
- Depending upon ceiling or wall construction reinforcement may be required at mounting locations.
- Continuous row: Install one fixture section at a time.
- Filler length 12" min/ 24" max.
- Filler may have internal driver, or powered by other fixture. See layout drawing for details.

GENERAL INSTALLATION

1. Determine filler location and measure length of filler needed. Mark cut line around housing (Discard side as indicated in figure 1).
2. Remove driver cover. Remove outside screws on one side to separate filler into halves lengthwise.

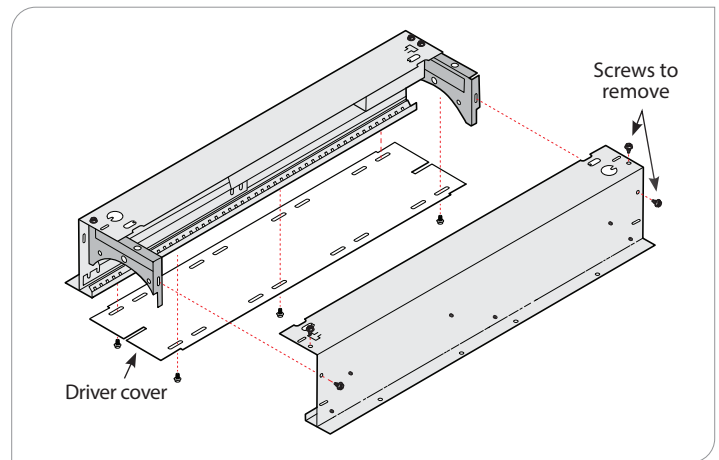
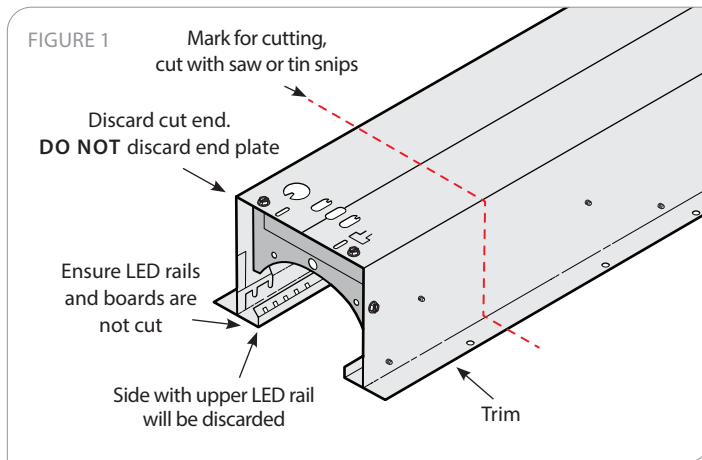

3. Remove end plate and driver cover support tabs from filler bodies.
4. Remove upper LED rails from filler bodies (May require loosening electrical connectors)
5. Cut filler bodies, trims and driver cover to required length and discard unneeded ends. (See Figure 1).
6. Align upper LED rails to cut end of filler and drill holes for #6 screws as required to install upper LED rails and end plates. LED boards will overlap.
7. Rewire LED boards and reassemble filler by reversing steps 2-4.

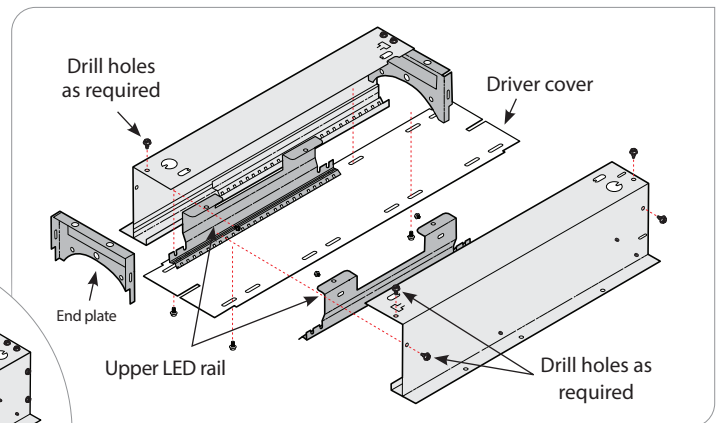
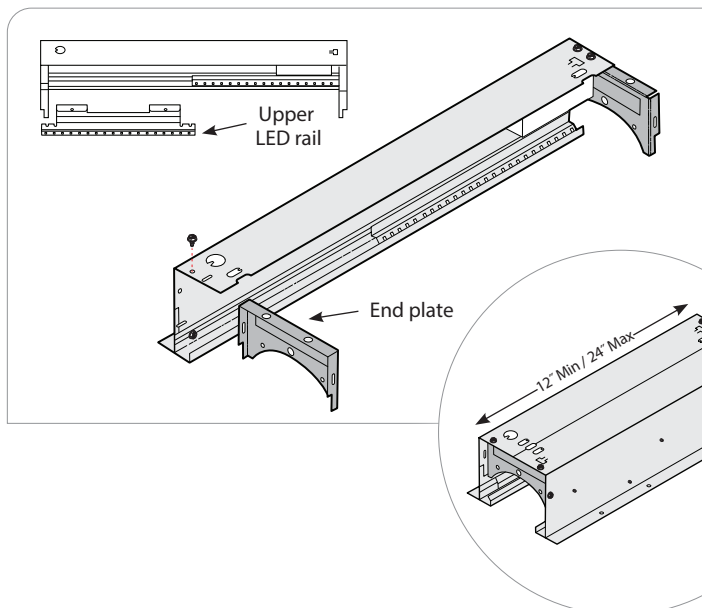

WARNING: Ground fixture in accordance with local and national electrical codes. Failure to do so may result in serious personal injury. Fixture Installations should ONLY be done by a qualified licensed electrical professional.

Stream2 | Recessed Linear Corner Installation

INSTALLATION INSTRUCTIONS



PRUDENTIAL LTG.

PRULITE.COM 213.746.0360

NOTE: Corners are powered by driver in previous fixture.

DO NOT remove foam inserts until step 3.

1. Remove wire covers from corners to reveal mounting slots. Install corner body into ceiling.
2. Remove driver covers from adjoining fixtures. Join fixtures to corner with 2x #8 screws, 2x u-nuts, and 2x aligner splines at each joint. Reinstall all wire and driver covers.
3. Remove foam inserts from corners (molded reflector cannot be removed).
4. Wearing gloves, install long film in both adjoining rows (runs into corner fixture).

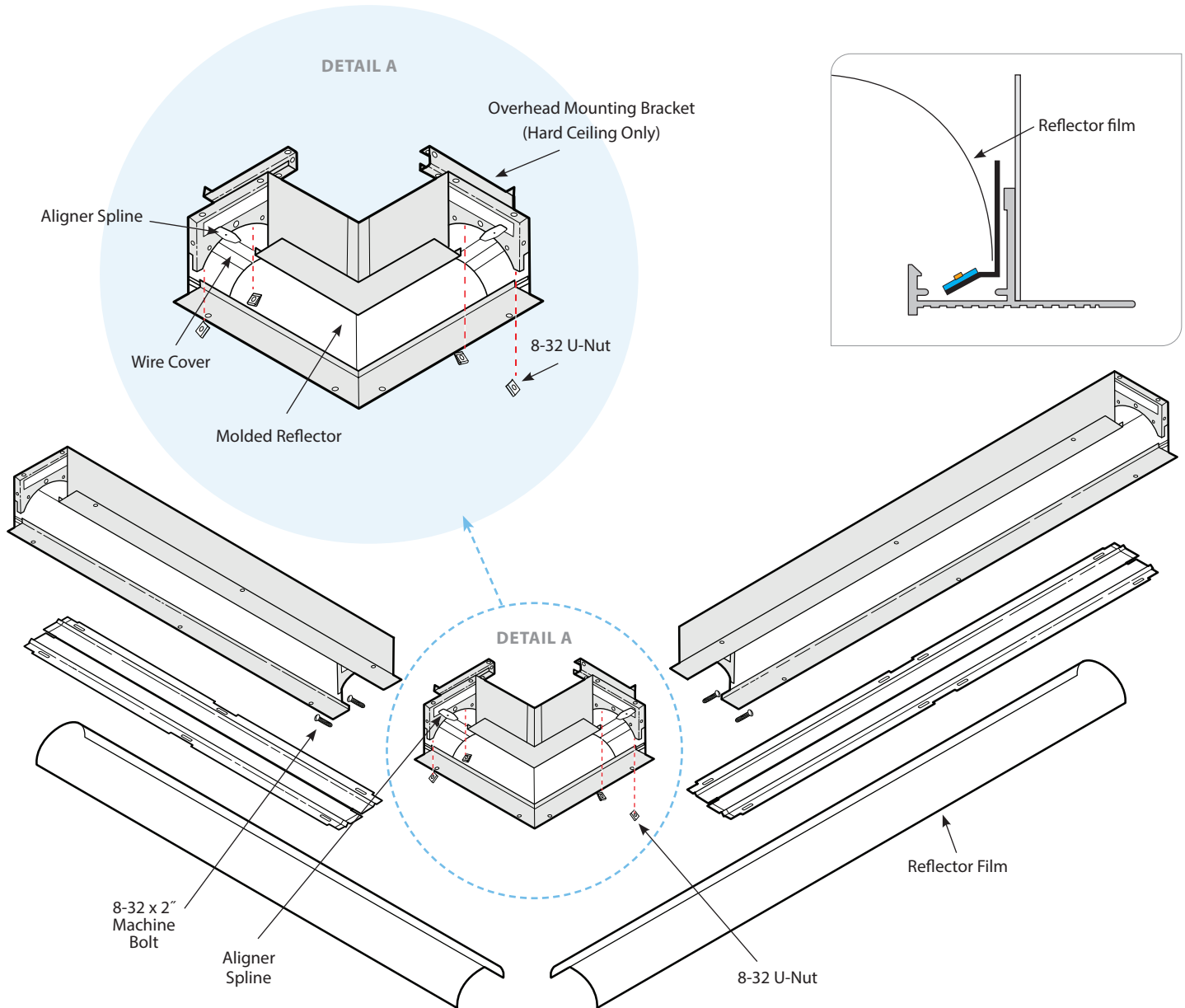

WARNING: Ground fixture in accordance with local and national electrical codes. Failure to do so may result in serious personal injury. Fixture Installations should ONLY be done by a qualified licensed electrical professional.

Stream2 | Recessed Linear Reflector Installation

MAINTENANCE INSTRUCTIONS



PRUDENTIAL LTG.

PRULITE.COM 213.746.0360

PLEASE READ THE FOLLOWING INSTRUCTIONS CAREFULLY:

Test LEDs and confirm they are all lit before beginning Reflector install.

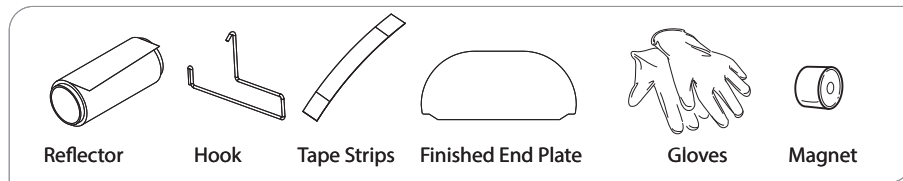

REFLECTOR INSTALLATION VIDEO

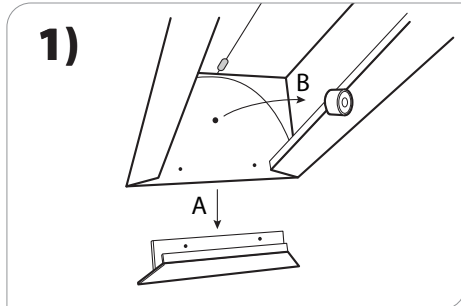

1) Remove trim (A) and magnet (B) from one end (DO NOT remove A from X7 ceilings).

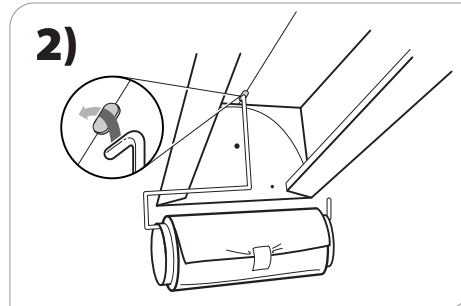

2) Hang reflector roll from same end using hook. Matte side of film will face down towards room when installed.

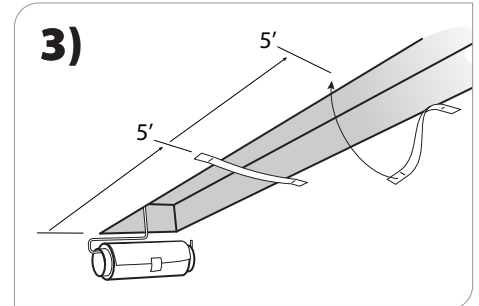

3) Apply tape strips provided about 5' apart along housing.

NOTE: Wait at least 24 hours after painting before using tape strips.

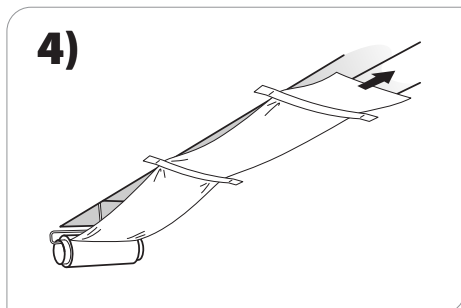

4) **USE GLOVES PROVIDED.** Pull reflector over entirety of housing row. Tighten roll to remove excess slack. Clamp roll to keep from unrolling.

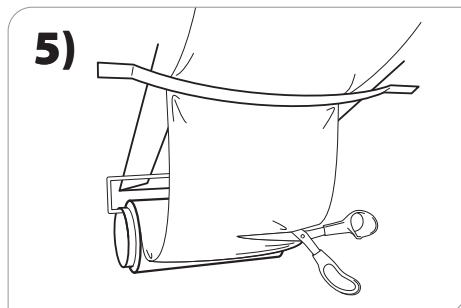

5) Cut reflector to fit — from side with excess reflector (hook & roll side). **DO NOT UNDER-CUT.** Make small cuts until reflector fits into housing, covering curved end plate.

For each corners: Reflector should go into corner housing 3/8" and overlap corner reflector ~1/4"

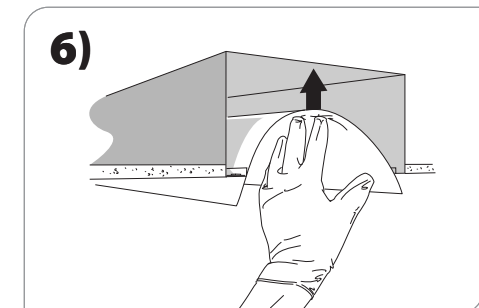

6) Push reflector into housing to proper position. Make sure no LED emitters are covered. Wire leads may need to be tucked away from emitters and reflector.

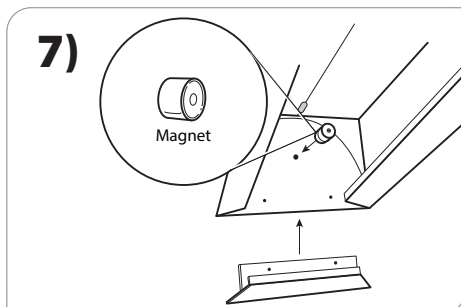

7) Reinstall magnet and trim (except on trimless X7 ceiling).

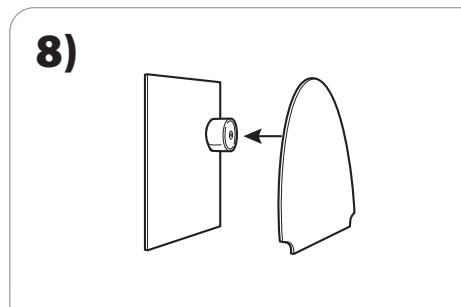

8) Install finish end plate to magnets on each end of row. Adjust end plate as needed to close gaps along reflector.

CLEANING INSTRUCTIONS:

Reflector film may be cleaned as needed. To avoid contaminating LED emitters, use only water and/or isopropyl alcohol solution on a clean wash cloth. Other cleaning chemicals could damage LED emitters.

WARNING: Ground fixture in accordance with local and national electrical codes. Failure to do so may result in serious personal injury. Fixture Installations should ONLY be done by a qualified licensed electrical professional.

Stream2 | Recessed Linear LED & Driver Replacement

MAINTENANCE INSTRUCTIONS



PRUDENTIAL LTG.

PRULITE.COM 213.746.0360

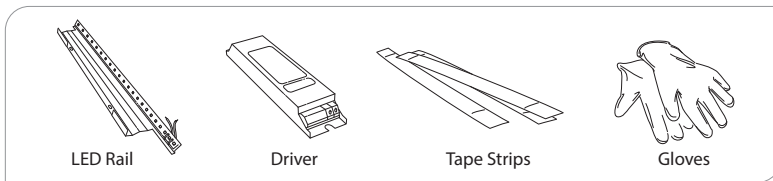

PLEASE READ THE FOLLOWING INSTRUCTIONS CAREFULLY:

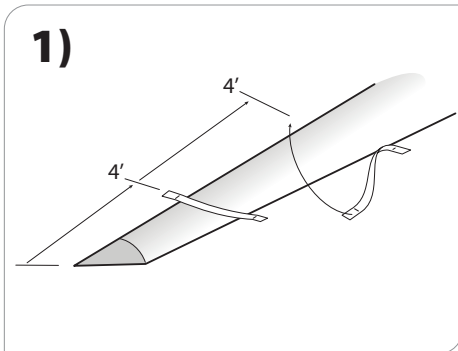

1) Locate faulty LED Rail or Driver. Starting at nearest end of row, attached tape strips approx 4' beyond faulty equipment.

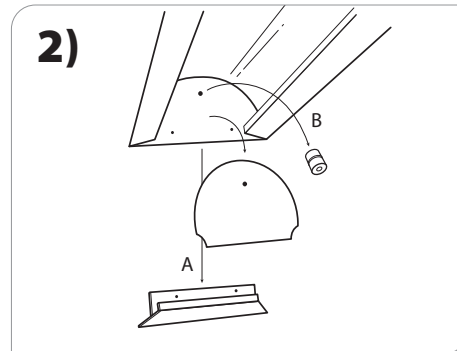

2) Remove end plate, magnet and end trim (when possible).

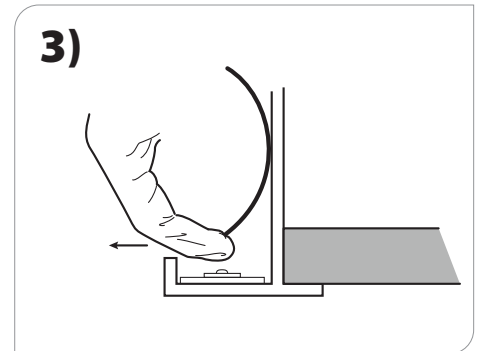

3) Use gloves provided. Gently lift bottom edge of reflector and remove from housing.

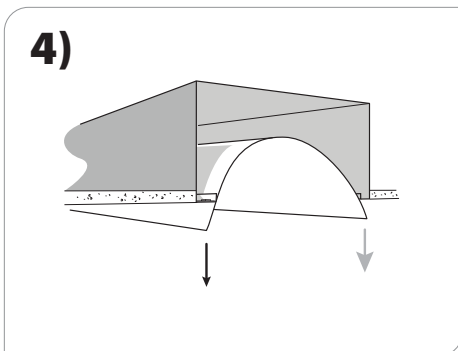

4) **USE GLOVES PROVIDED.** Pull reflector over entirety of housing row. Tighten roll to remove excess slack. Clamp roll to keep from unrolling.

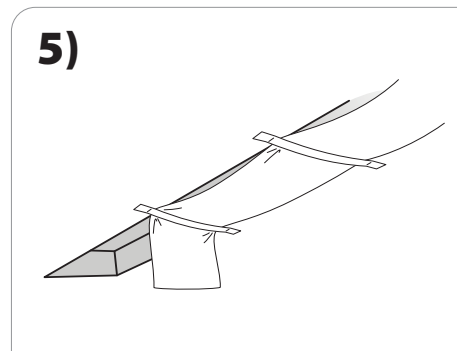

5) Let reflector rest on tape strips

Remove sheet metal cover held on by screws to access wiring. Replace faulty equipment and reinstall all components in reverse order.

WARNING: Ground fixture in accordance with local and national electrical codes. Failure to do so may result in serious personal injury. Fixture Installations should ONLY be done by a qualified licensed electrical professional.