



P33 | Recessed Linear

3" Slot, TechZone 4





INSTALLATION INSTRUCTIONS

X1, X1M, X2, X6 — T-BAR

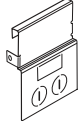
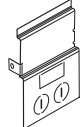
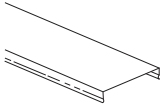

PRUDENTIAL LTG.

PRULITE.COM 213.746.0360

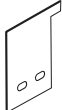
PARTS (SHIPPED SEPARATELY)	PART NO.	DESCRIPTION
	101915	Finish Plate X1 / X1M
	101916	Finish Plate X2 / X6
	100-00170-10	Lens
	100-00190-14	#8-32 x 3/8" SL HWH Type F Screw
	100-00286-14	#6-32 x 3/16" Phil PH Type 23 Screw
	82484	Lens Removal Tool
	39837	T-Bar Clip
	73321	Housing Aligner Spline

WARNING: Ground fixture in accordance with local and national electrical codes. Failure to do so may result in serious personal injury.



P33 | Recessed Linear 3" Slot, TechZone 4

INSTALLATION INSTRUCTIONS

X1, X1M, X2, X6 — T-BAR

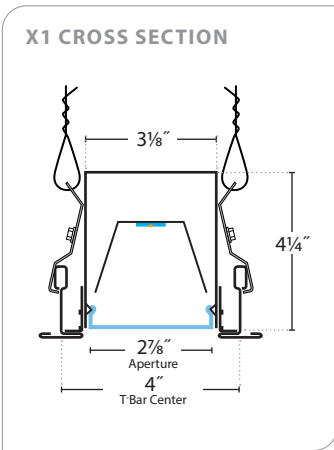

NOTES

1. Additional support to structural member may be required. Refer to local building codes.
2. Individual fixtures not intended for row mounting.

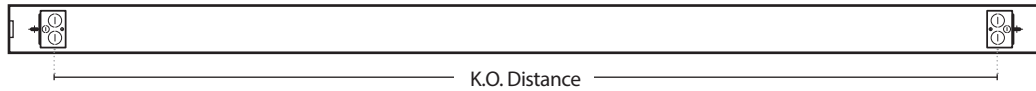
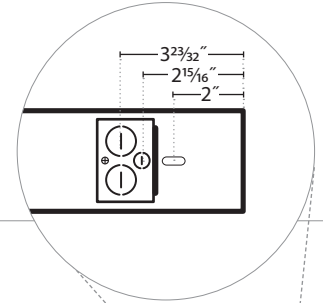
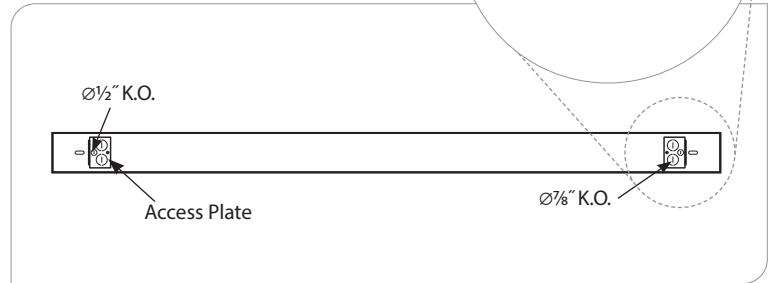
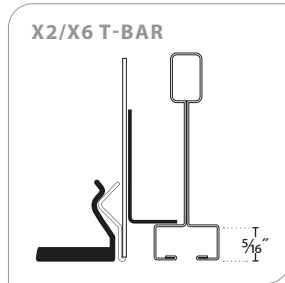

INDIVIDUAL: **ROW DIRECTION: INSTALL FROM LEFT TO RIGHT**

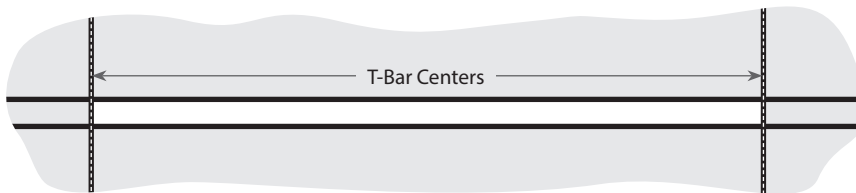

Fixture	K.O. Distance
24" (2')	16 5/8"
36" (3')	28 5/8"
48" (4')	40 5/8"
60" (5')	52 5/8"
72" (6')	64 5/8"
84" (7')	76 5/8"
96" (8')	88 5/8"

ROW:

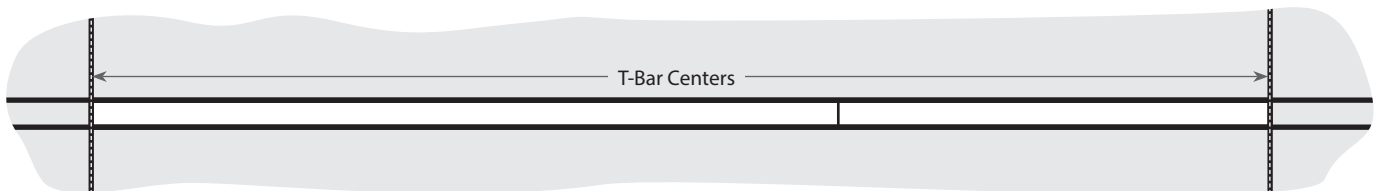

WARNING: Ground fixture in accordance with local and national electrical codes. Failure to do so may result in serious personal injury.



P33 | Recessed Linear

3" Slot, TechZone 4

INSTALLATION INSTRUCTIONS

X1, X1M, X2, X6 — T-BAR



PRUDENTIAL LTG.

PRULITE.COM 213.746.0360

IDENTIFYING FIXTURES (AS SHIPPED)

INDIVIDUAL:
Finish Plates

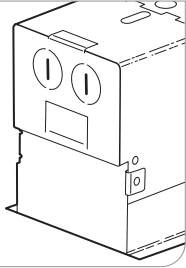

**INTERMEDIATE
OR START/END:**
No Finish Plates

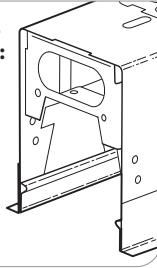

INDIVIDUAL MOUNTING

1. Lift fixture above grid and lower until fixture is resting on t-bars (Figure 1).
2. Install t-bar clips with #8 x 3/8" HWH self tap screws (Figure 2).
3. Attach wire support (By others) (Figure 3).
4. Make all wiring connections through access plate (Figure 4).
5. Install lens.

FIGURE 1:

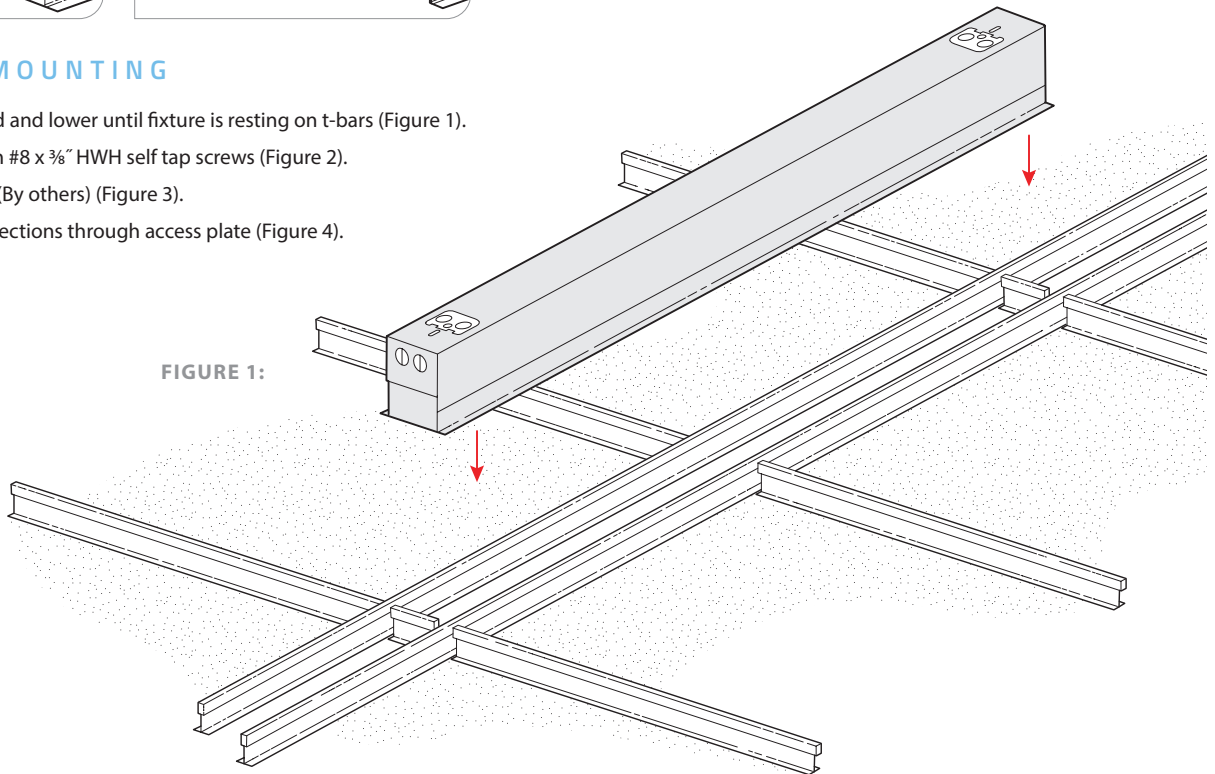

FIGURE 2:

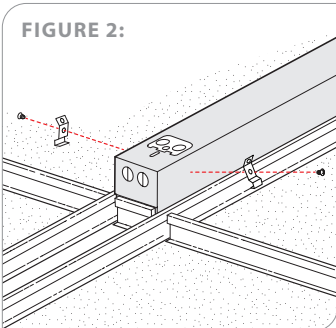

FIGURE 3:

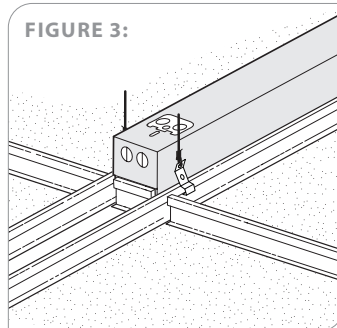

FIGURE 4:

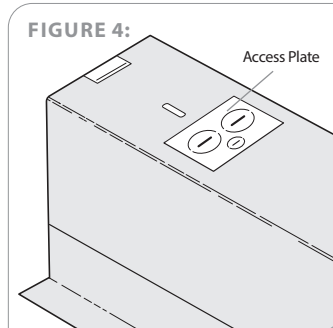
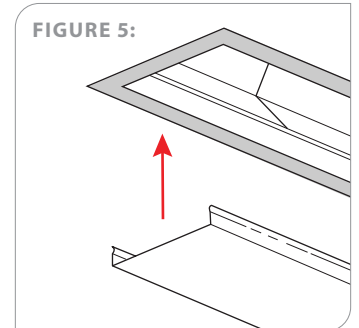

FIGURE 5:



WARNING: Ground fixture in accordance with local and national electrical codes. Failure to do so may result in serious personal injury.



Prudential Ltg. reserves the right to change design specifications or materials without notice. Please visit prulite.com for most current data.
© 2015 All rights reserved – All products manufactured at: Prudential Ltg. 1774 E. 21st Street, Los Angeles, CA 90058



P33 | Recessed Linear

3" Slot, TechZone 4

INSTALLATION INSTRUCTIONS



X1, X1M, X2, X6 — T-BAR

ROW MOUNTING

1. Install start fixture per instructions on page 2.
2. On second or subsequent fixtures, remove reflector mounting screws (Figure A). Leave safety cables attached (Figure B).
3. Install (2) housing aligner splines per seam, #8 x 3/8" HWH self tap (Figures C & D).
4. Slide intermediate/end fixture onto start/intermediate fixture (Figure E).
5. Install (2) fixture joining screws per seam, #8 x 3/8" HWH self tap (Figure F).
6. Install finish plates (one at each end of the row) using #6-32 x 1/4" (Figures H & I).
7. Refer to filler kit instructions to field trim filler kits (where used).
8. Last lens in row to be field trimmed to size (Figure J).

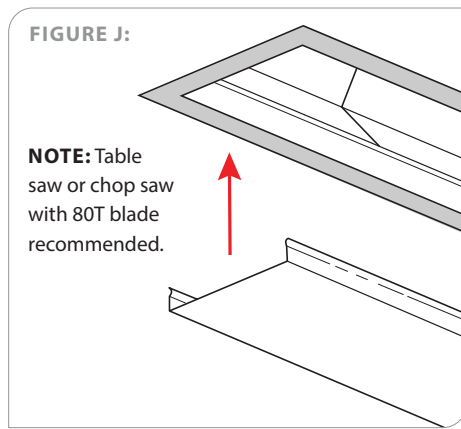
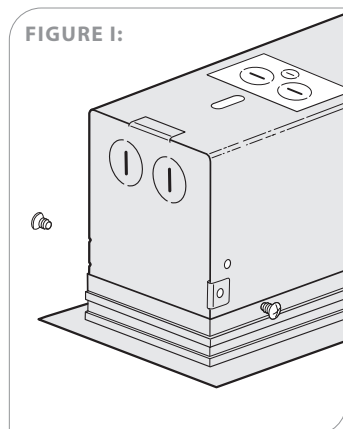
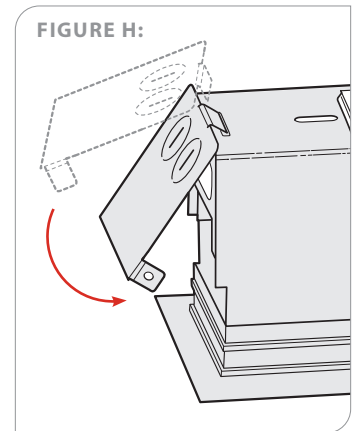
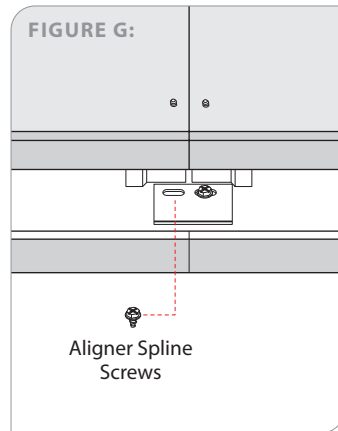
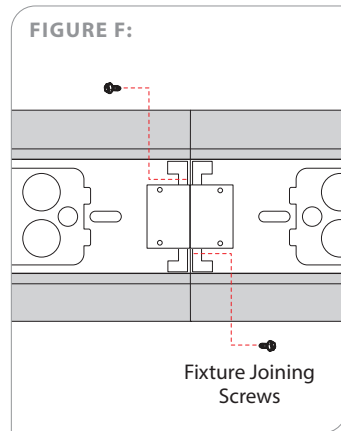
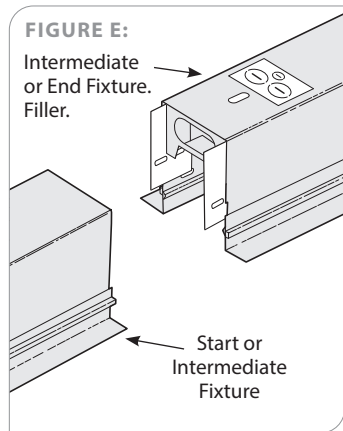
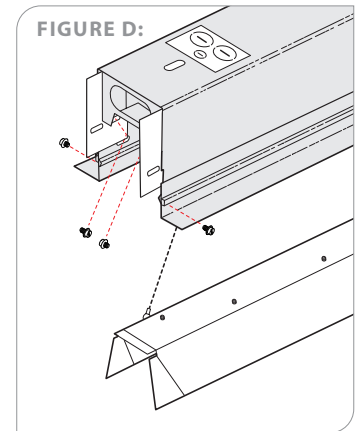
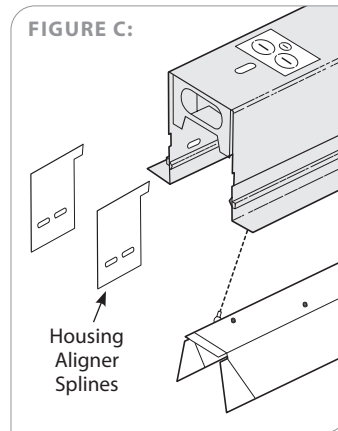
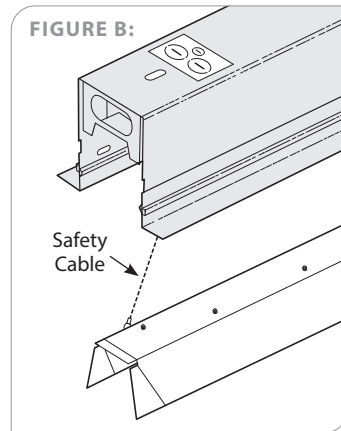
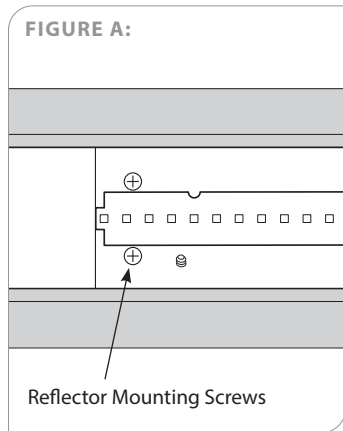

WARNING: Ground fixture in accordance with local and national electrical codes. Failure to do so may result in serious personal injury.



P33 | Recessed Linear 3" Slot, TechZone 4

INSTALLATION INSTRUCTIONS



PRUDENTIAL LTG.

PRULITE.COM 213.746.0360

FILLER KIT

INSTALLATION

1. Disassemble Filler.

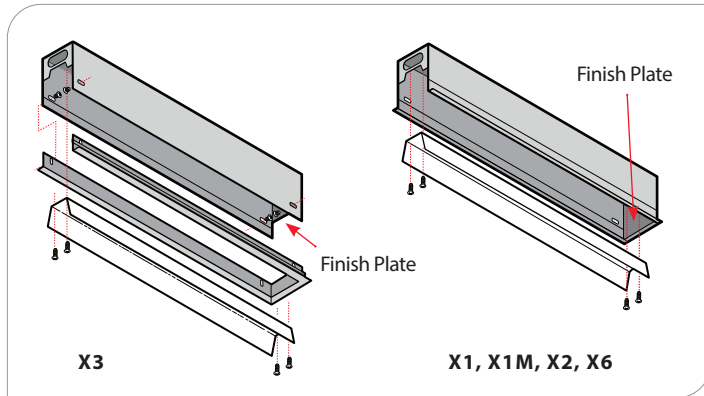

2. Mark cut line and cut filler body.

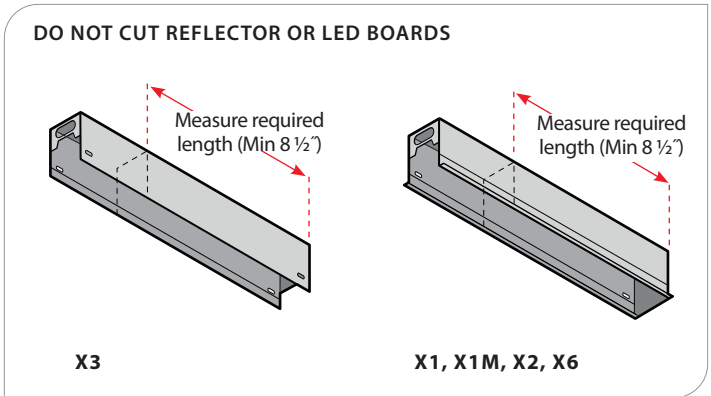

3. Measure trim and mark for cutting.

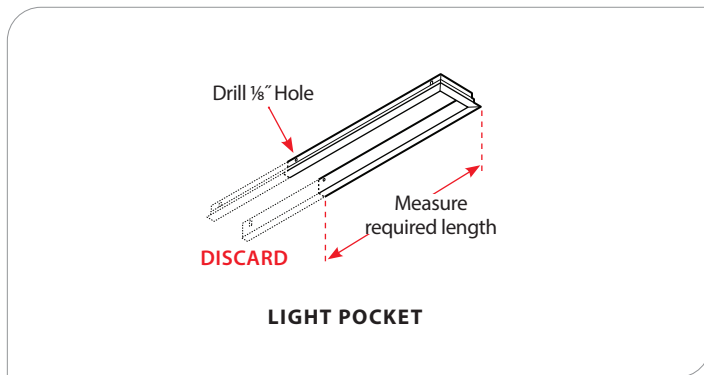

4. Drill and fix end plate and trim.

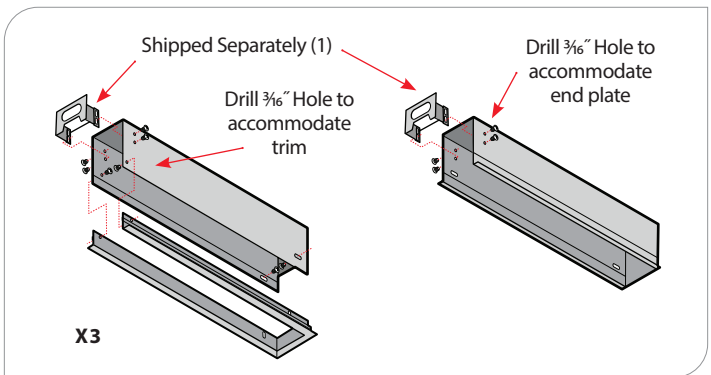

5. Install spacers to reflectors to filler.

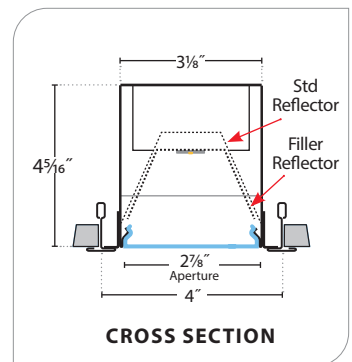
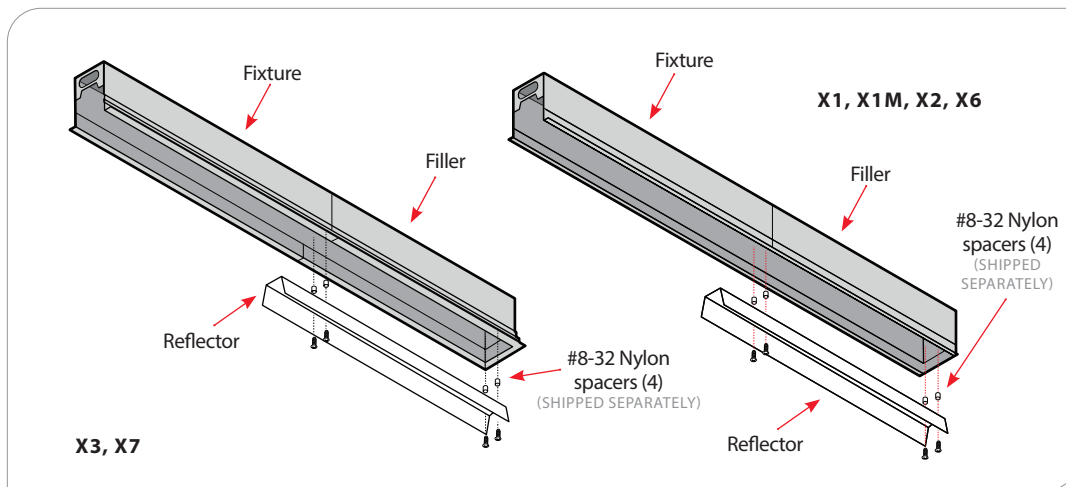

WARNING: Ground fixture in accordance with local and national electrical codes. Failure to do so may result in serious personal injury.



Prudential Ltg. reserves the right to change design specifications or materials without notice. Please visit prulite.com for most current data.
© 2015 All rights reserved - All products manufactured at: Prudential Ltg. 1774 E. 21st Street, Los Angeles, CA 90058