



P33 | Recessed Linear

3" Slot, TechZone 4





INSTALLATION INSTRUCTIONS

X3 — HARD CEILING



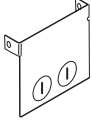

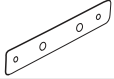
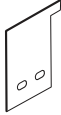

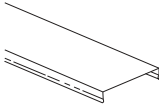
PRUDENTIAL LTG.

PRULITE.COM 213.746.0360

PARTS (SHIPPED SEPARATELY)	PART NO.	DESCRIPTION
	101917	Finish Plate X3
	82484	Lens Removal Tool
	29513	Aligner/Seam Joiner
	73321	Housing Aligner Spline
	100-00190-14	#8-32 x 3/8" SL HWH Type F Screw
	100-00286-14	#6-32 x 3/16" Phil PH Type 23 Screw
	100-00170-10	Lens

MOUNTING BRACKET:

	100-00126-14	1/4-20 Fender Washer
	100-00165-14	1/4-20 Hex Nut
	23161	Bracket Leg 5 3/4"
	134810	Overhead Mounting Bracket Yoke with Nut
	100-00005-14	1/4 -20 x 3/8" Round Head Machine Screw

WARNING: Ground fixture in accordance with local and national electrical codes. Failure to do so may result in serious personal injury.



Prudential Ltg. reserves the right to change design specifications or materials without notice. Please visit prulite.com for most current data.
© 2015 All rights reserved – All products manufactured at: Prudential Ltg. 1774 E. 21st Street, Los Angeles, CA 90058



P33 | Recessed Linear

3" Slot, TechZone 4

INSTALLATION INSTRUCTIONS

X3 — HARD CEILING



PRUDENTIAL LTG.

PRULITE.COM 213.746.0360

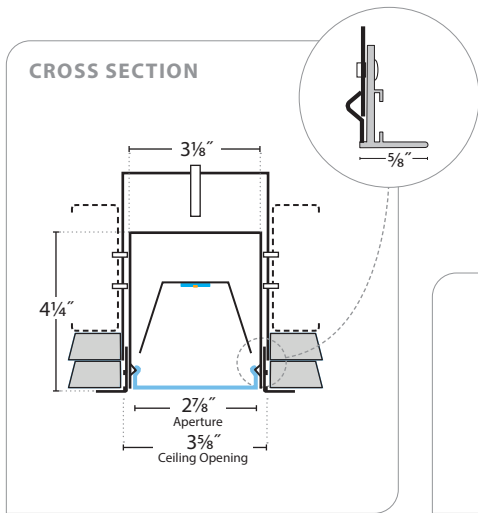

NOTES

1. Install fixture and joining hardware, as required.
2. Additional support to structural member may be required. Refer to local building codes.

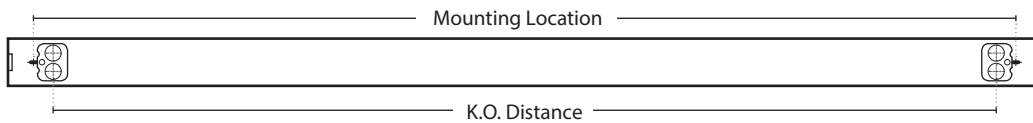
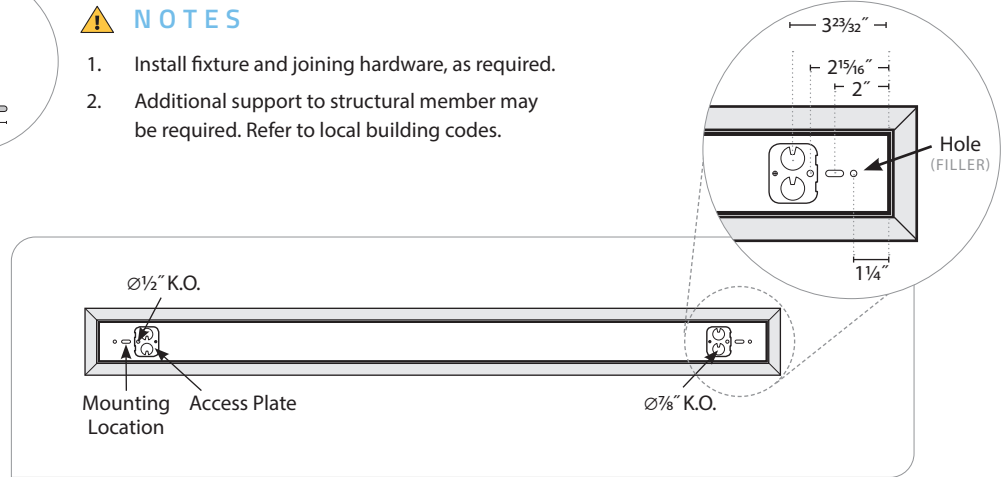

CEILING OPENING ROUGH IN DIMENSIONS

INDIVIDUAL: -----> ROW DIRECTION: INSTALL FROM LEFT TO RIGHT

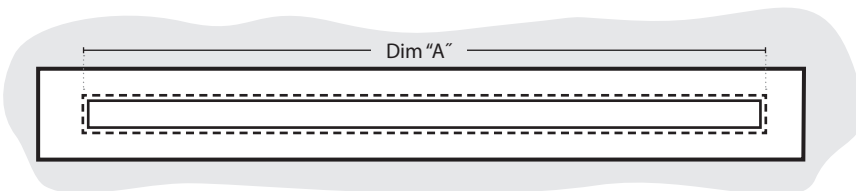

Fixture	Mounting Location	K.O. Distance	Ceiling Opening Dim 'A'
24" (2')	20"	16 5/8"	24 5/8"
36" (3')	32"	28 5/8"	36 5/8"
48" (4')	44"	40 5/8"	48 5/8"
60" (5')	56"	52 5/8"	60 5/8"
72" (6')	68"	64 5/8"	72 5/8"
84" (7')	80"	76 5/8"	84 5/8"
96" (8')	92"	88 5/8"	96 5/8"

ROW:

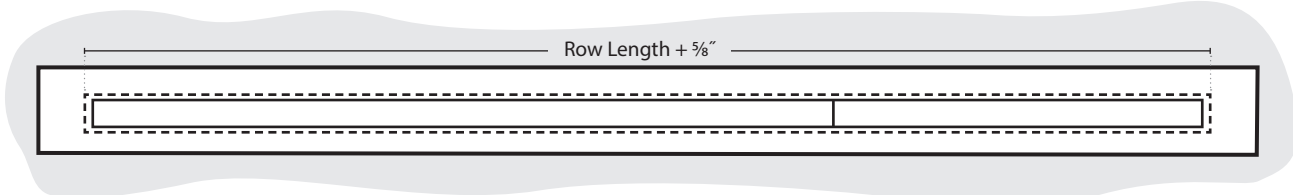

WARNING: Ground fixture in accordance with local and national electrical codes. Failure to do so may result in serious personal injury.



P33 | Recessed Linear

3" Slot, TechZone 4

INSTALLATION INSTRUCTIONS

X3 — HARD CEILING



PRUDENTIAL LTG.

PRULITE.COM 213.746.0360

IDENTIFYING FIXTURES

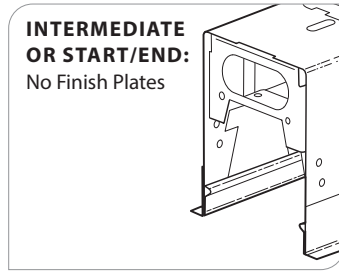
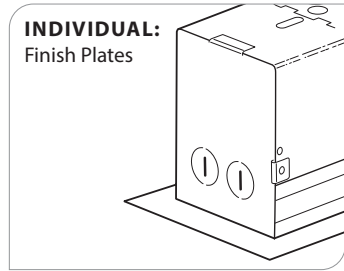

INDIVIDUAL MOUNTING

1. Assemble and install mounting brackets and secure bracket legs to studs or ceiling joists (Figure 1).
2. Remove reflector(s) from housing, leaving safety cables in place.
3. Mount fixture to mounting brackets and secure using 1/4" washer and nut.
4. Make all wiring connections thru access plate(s) (Figure 2).
5. Replace reflector(s).
6. Install lens.

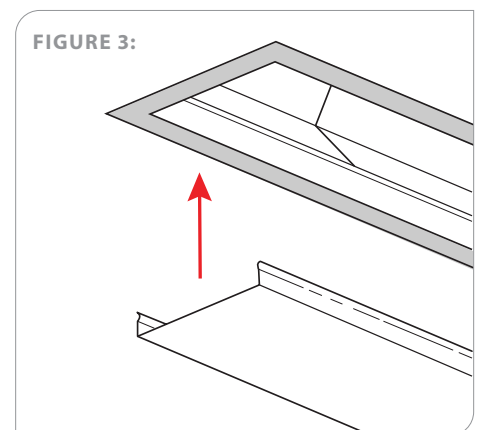
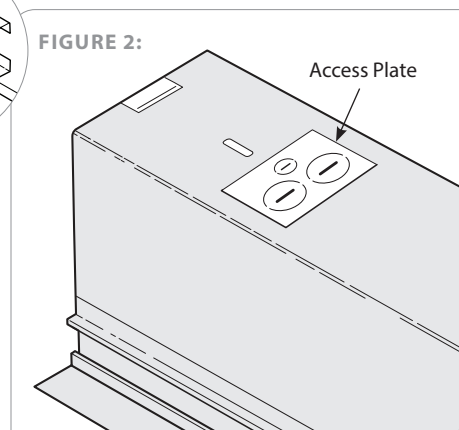
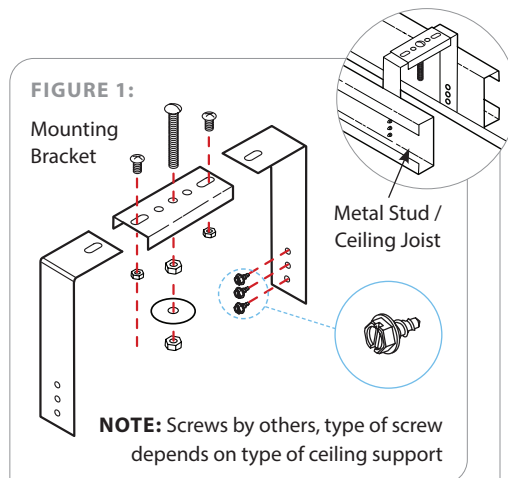
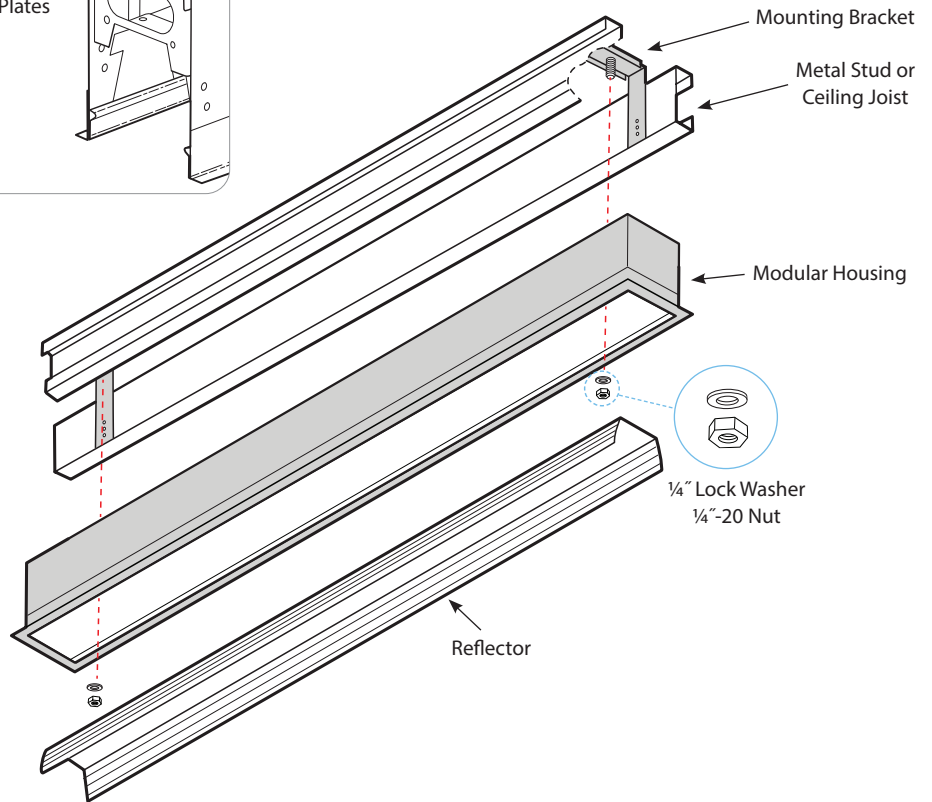

WARNING: Ground fixture in accordance with local and national electrical codes. Failure to do so may result in serious personal injury.



P33 | Recessed Linear

3" Slot, TechZone 4

INSTALLATION INSTRUCTIONS



PRUDENTIAL LTG.

PRULITE.COM 213.746.0360

X3 — HARD CEILING

ROW MOUNTING

1. Install start fixture per instructions on page 2.
2. On second or subsequent fixtures, remove reflector mounting screws (Figure A). Leave safety cables attached (Figure B).
3. Install (2) housing aligner splines per seam, #8 x 3/8" HWH self tap (Figures C & D).
4. Slide intermediate/end fixture onto start/intermediate fixture (Figure E).
5. Install (2) fixture joining screws per seam, #8 x 3/8" HWH self tap (Figure F).
6. Install (2) aligner spline screws per seam, #8 x 3/8" HWH self tap (Figure G).
7. Install finish plates (one at each end of the row) using #6-32 x 3/16" (Figures H & I).
8. Refer to filler kit instructions to field trim filler kits (where used).
9. Last lens in row to be field trimmed to size (Figure J).

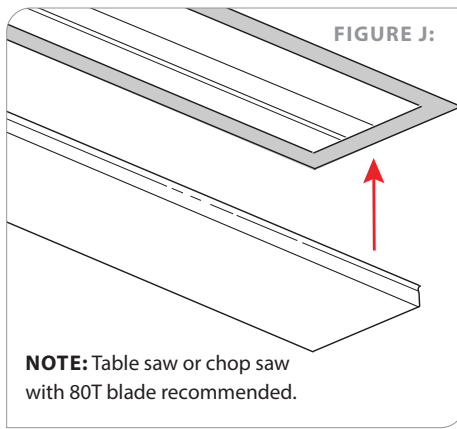
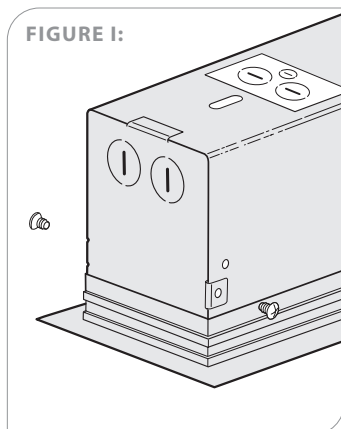
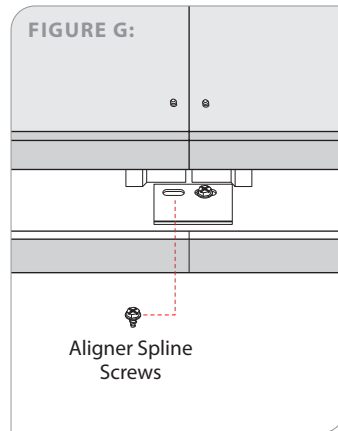
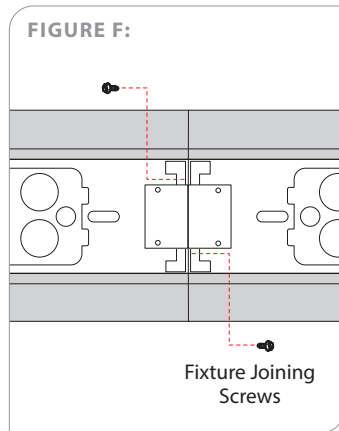
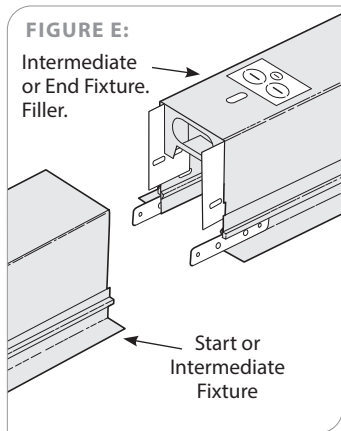
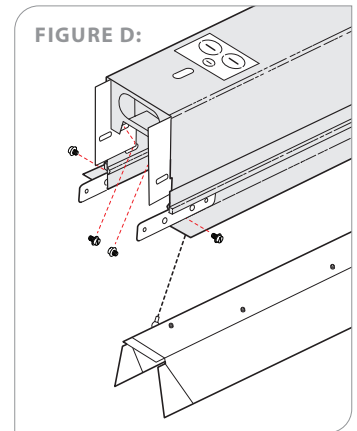
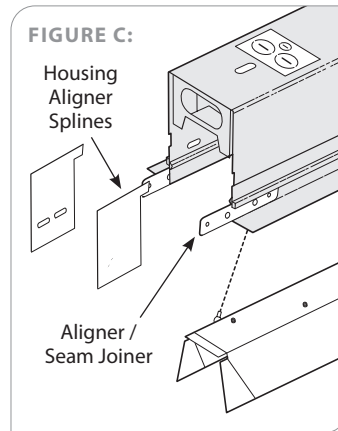
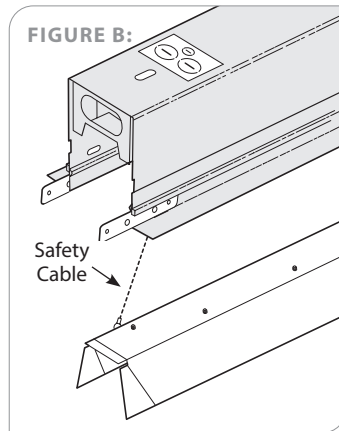
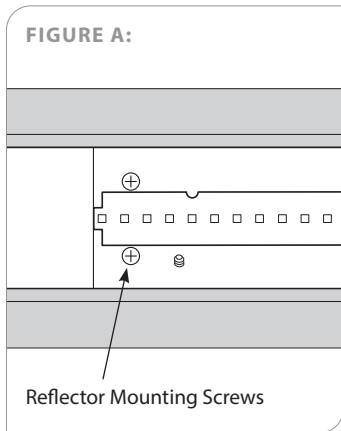

WARNING: Ground fixture in accordance with local and national electrical codes. Failure to do so may result in serious personal injury.



P33 | Recessed Linear 3" Slot, TechZone 4

INSTALLATION INSTRUCTIONS



PRUDENTIAL LTG.

PRULITE.COM 213.746.0360

FILLER KIT

INSTALLATION

1. Disassemble Filler.

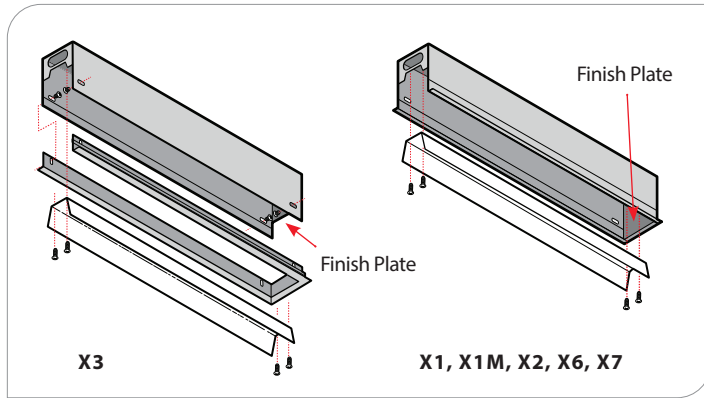

2. Mark cut line and cut filler body.

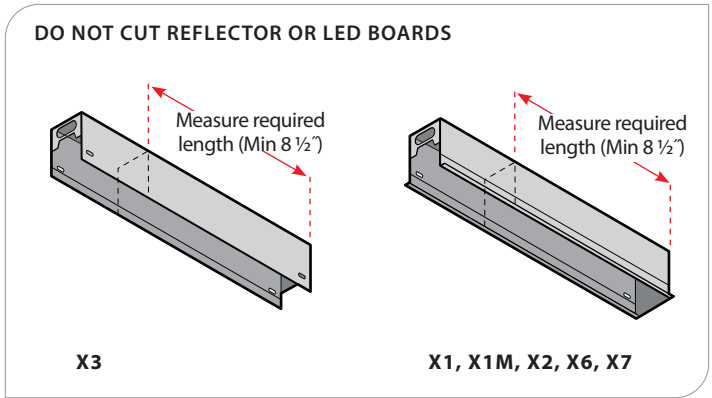

3. Measure trim and mark for cutting.

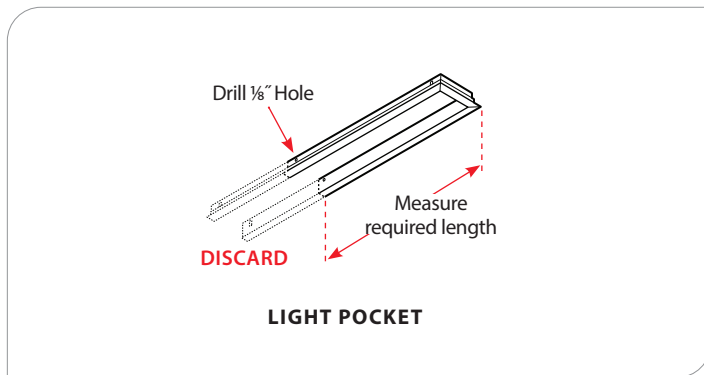

4. Drill and fix end plate and trim.

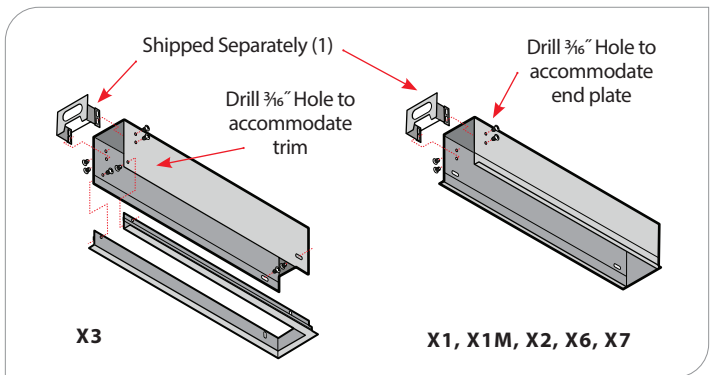

5. Install spacers to reflectors to filler.

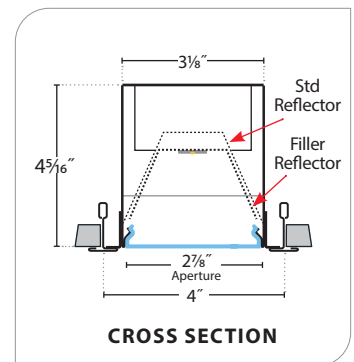
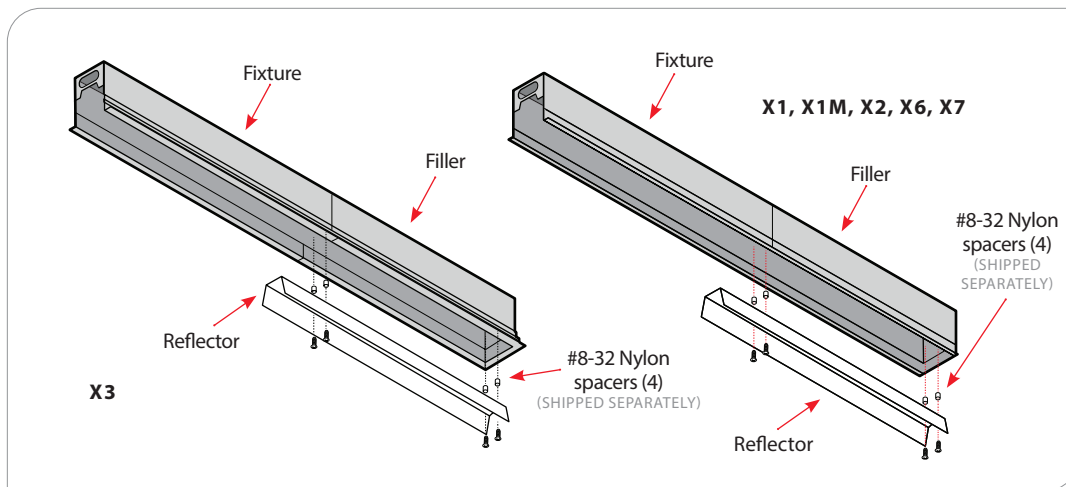

WARNING: Ground fixture in accordance with local and national electrical codes. Failure to do so may result in serious personal injury.



Prudential Ltg. reserves the right to change design specifications or materials without notice. Please visit prulite.com for most current data.
© 2015 All rights reserved - All products manufactured at: Prudential Ltg. 1774 E. 21st Street, Los Angeles, CA 90058