









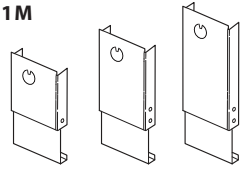
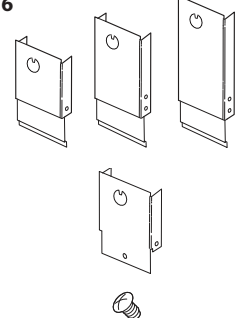

# P23 | Cove & Perimeter

## 2" Perimeter

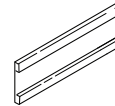
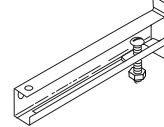
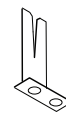
### INSTALLATION INSTRUCTIONS

#### X1, X1M, X2, X6 (T-BAR)

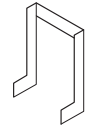

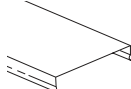
PARTS LIST	PART NO.	DESCRIPTION
<b>FINISH PLATES:</b>		
<b>X1, X1M</b> 	91450	Flush (X1M, X1M)
	91451	Regress 1 (X1M, X1M)
	91452	Regress 3 (X1M, X1M)
<b>X2, X6</b> 	91453	Flush (X2, X6)
	91454	Regress 1 (X2, X6)
	91455	Regress 3 (X2, X6)
	91459	Wall to Wall (WTW)
	100-00021-14	#8 x 1/4" Phil Pan Head Screw, Type A
	See Order	Wall Rail Extrusion
	100638	Mounting Bracket Assembly
	101504	Body Joiner
	100-00019-14	#8 x 1/4" HWH SMS Phil Screw, Type A
	100-00273-14	7/64" x 1" Roll Pin
	100-00086-14	#6 x 3/8" Phil Pan Tek Screw
	100-00084-08	Troffer Clamp
	101274	Reflector Removal Tool
	82484	Lens Removal Tool
	See Order	Lens

**WARNING:** Ground fixture in accordance with local and national electrical codes. Failure to do so may result in serious personal injury.



# P23 | Cove & Perimeter

## 2" Perimeter

### INSTALLATION INSTRUCTIONS

#### X1, X1M, X2, X6 (T-BAR)



PRUDENTIAL LTG.

PRULITE.COM 213.746.0360

#### NOTES

1. Wall must extend at a minimum up to top of aluminum wall rail edge. (See detail B).
2. Fixture mounting system must be installed prior to ceiling installation.
3. Exposed wall must be finished above finish ceiling (see table, right) prior to fixture installation.

#### FINISHED CEILING HEIGHT

CEILING	EXPOSED WALL
Flush	2"
Reg1	3"
Reg3	5"

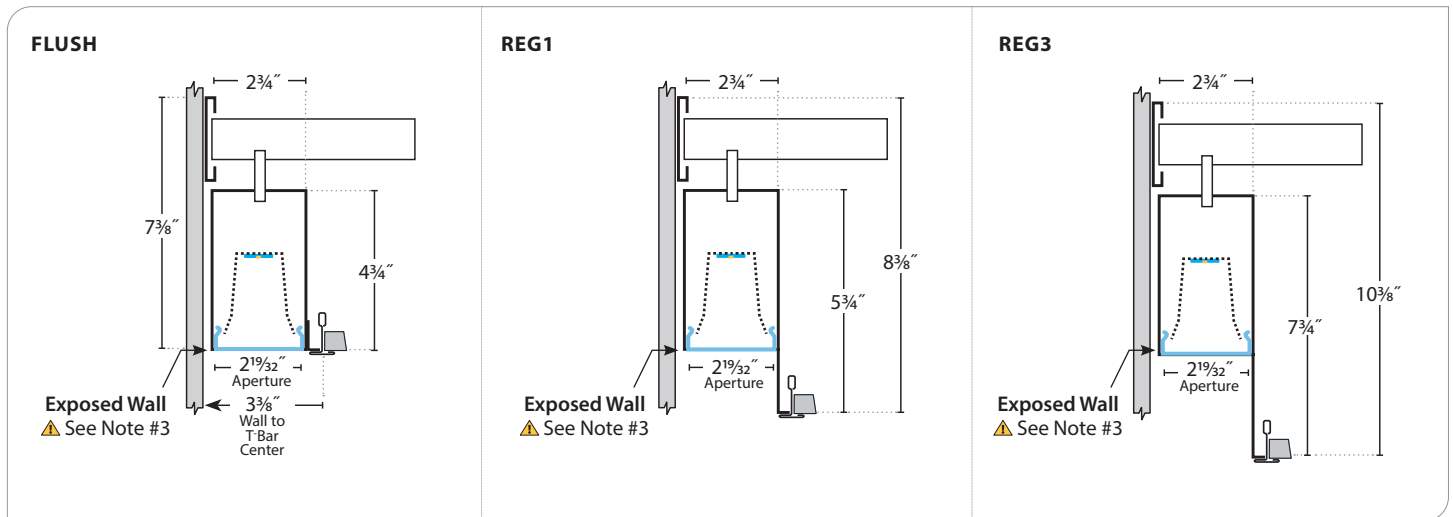

#### MOUNTING RAIL INSTALLATION

See row diagram or Prudential Ltg. plan layout (If provided). Begin all row mounting from left to right facing wall surface (see arrows).

1. Facing wall, Install first aluminum wall rail (See Dim "A") above finish ceiling line to reinforced wall with screws (provided by others). (See detail A & B). Field trim last rail in row.
2. Turn mounting brackets into place on wall rail at fixture mounting hole locations.
3. Secure with wire supports (Provided by others) from mounting brackets to overhead support structure.

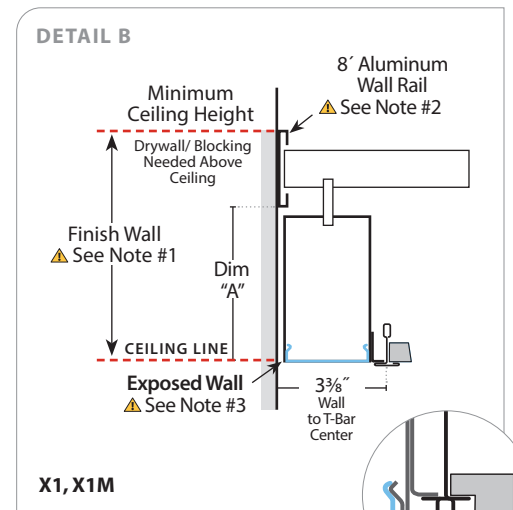
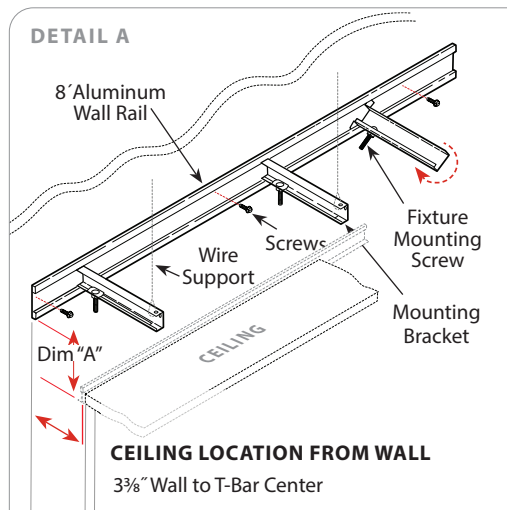

WALL RAIL MOUNTING HEIGHT	
CEILING	DIM "A"
Flush	5"
Reg1	6"
Reg3	8"

**WARNING:** Ground fixture in accordance with local and national electrical codes. Failure to do so may result in serious personal injury.



# P23 | Cove & Perimeter

## 2" Perimeter

### INSTALLATION INSTRUCTIONS



PRUDENTIAL LTG.

PRULITE.COM 213.746.0360

## X1, X1M, X2, X6 (T-BAR)

### FIXTURE INSTALLATION

1. To remove LED reflector assembly and expose mounting obrounds and driver wire leads, insert reflector removal tool and pull out at each end of reflector so spring clips (4) disengage from clip support bracket. (See figure 1).
2. If installing in rows, install finish plate with (2) #8 x 1/4" screws. (See detail C).
3. Lift the fixture assembly through ceiling opening and secure fixture to mounting bracket with toothlock washer and 1/4-20 hex nut provided. (See detail C).
4. Secure fixtures end to end with (2) body joiner and (2) #8 x 1/4" screws (2) aligner pins per seam. (See joining detail on page 4).
5. Repeat steps 1 and 3 to install remaining fixtures and corners in row.

DETAIL C

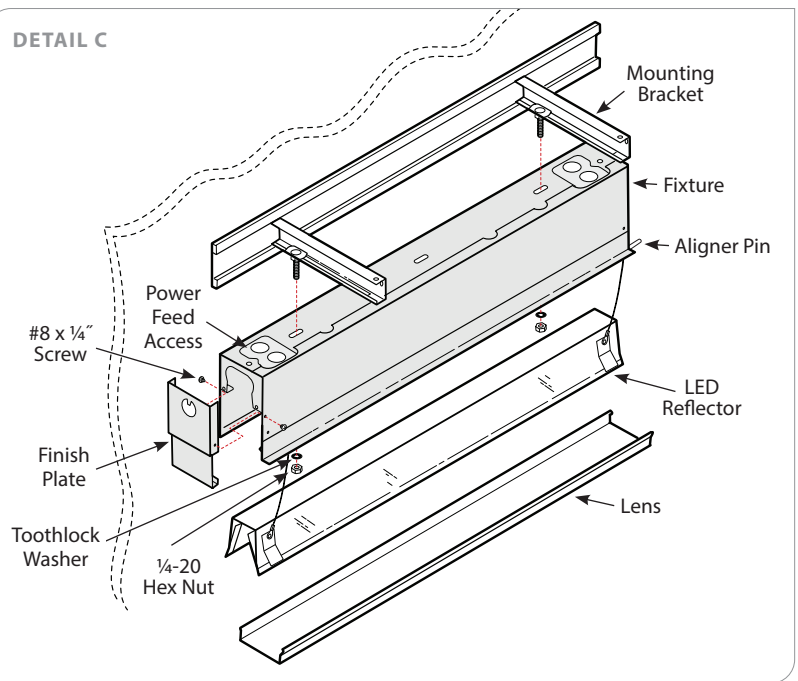

### REFLECTOR DETAILS

FIGURE 1: REFLECTOR REMOVAL DETAIL

Remove reflector assembly to expose mounting obrounds and driver wire leads, squeeze and pull out at each end of reflector so spring clips disengage from clip support bracket.

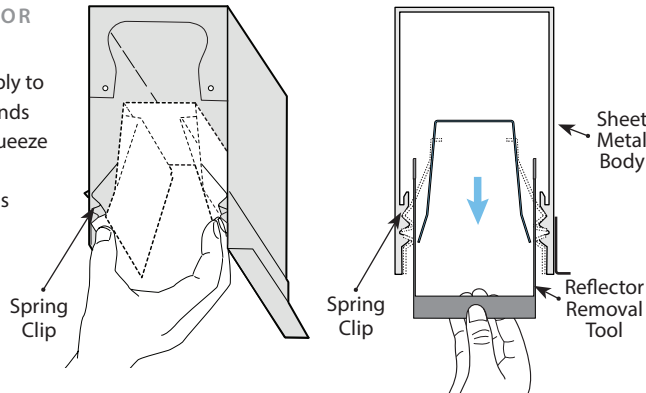
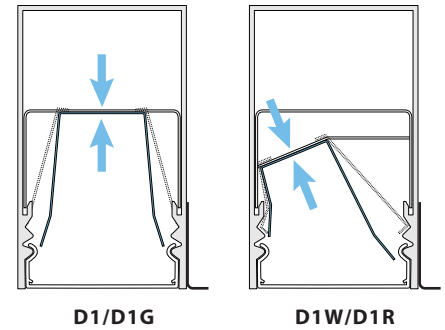
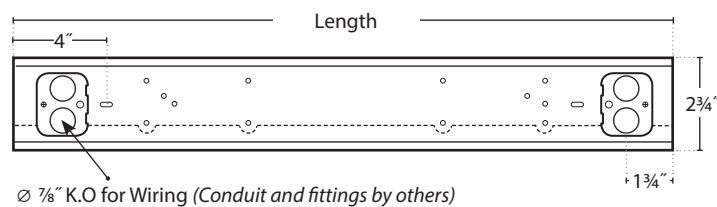

FIGURE 4: REFLECTOR POSITION



### INDIVIDUAL MOUNTING:



### ROUGH-IN DIMENSIONS:

FIXTURE LENGTH	LIGHT POCKET CEILING OPENING		WALL TO WALL CEILING OPENING	
	LENGTH	WIDTH	LENGTH	WIDTH
24"	24 5/8"	x 3 3/8"	24 1/2"	x 3 3/8"
36"	36 5/8"		36 1/2"	
48"	48 5/8"		48 1/2"	
72"	72 5/8"		72 1/2"	
84"	84 5/8"		84 1/2"	
96"	96 5/8"		96 1/2"	

**WARNING:** Ground fixture in accordance with local and national electrical codes. Failure to do so may result in serious personal injury.



Prudential Ltg. reserves the right to change design specifications or materials without notice. Please visit [prulite.com](http://prulite.com) for most current data.  
© 2015 All rights reserved - All products manufactured at: Prudential Ltg. 1774 E. 21st Street, Los Angeles, CA 90058



# P23 | Cove & Perimeter 2" Perimeter

## INSTALLATION INSTRUCTIONS

X1, X1M, X2, X6 (T-BAR)



PRUDENTIAL LTG.

PRULITE.COM 213.746.0360

### JOINING DETAIL

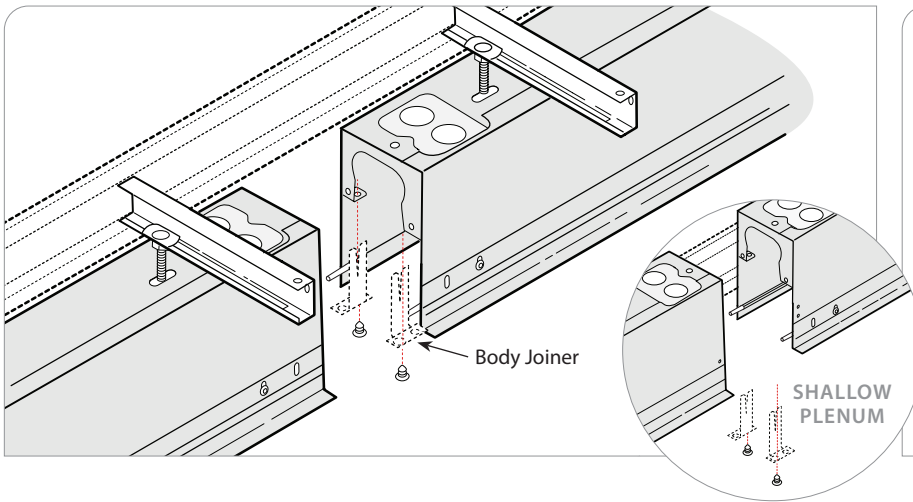
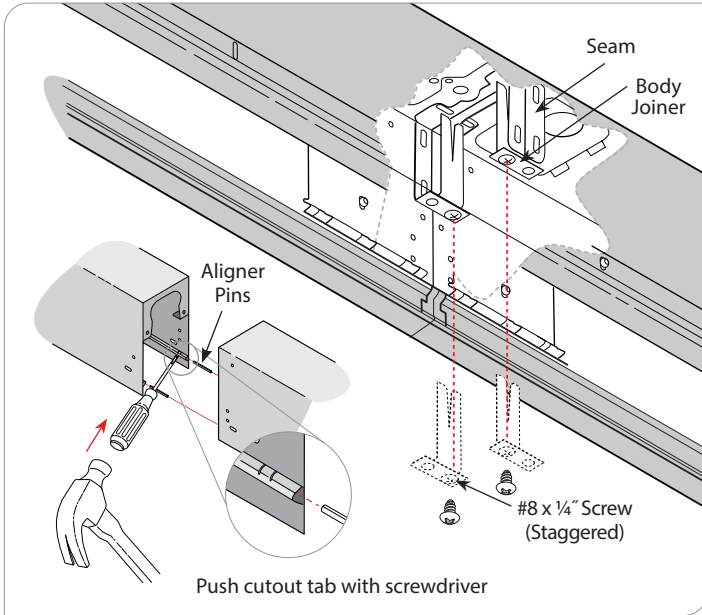

### REFLECTOR POSITION

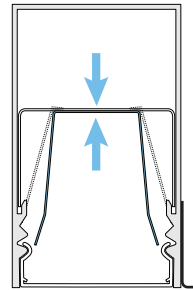

D1 / MWG / MBW

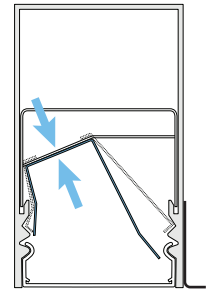

MWW

**WARNING:** Ground fixture in accordance with local and national electrical codes. Failure to do so may result in serious personal injury.



Prudential Ltg. reserves the right to change design specifications or materials without notice. Please visit [prulite.com](http://prulite.com) for most current data.  
© 2015 All rights reserved - All products manufactured at: Prudential Ltg. 1774 E. 21st Street, Los Angeles, CA 90058



# P23 | Cove & Perimeter

## 2" Perimeter

### INSTALLATION INSTRUCTIONS



PRUDENTIAL LTG.

PRULITE.COM 213.746.0360

## SHALLOW PLENUM

### NOTES

1. Finish wall must be completed (minimum) to top of fixture edge (See detail B).
2. Fixture mounting system and fixture must be installed prior to ceiling installation.
3. Exposed wall must be finished 2" above ceiling prior to fixture flush installation. (See detail B).
4. Plenum height must be 5/4" minimum from ceiling line. (See detail B).

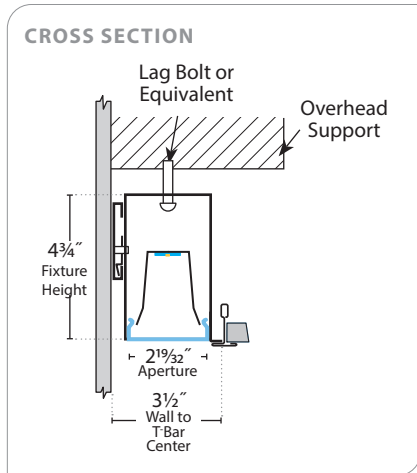

### MOUNTING RAIL INSTALLATION

See row diagram or Prudential Ltg. plan layout (If provided). Begin all row mounting from left to right facing wall surface (see arrows).

Facing wall, Install first aluminum wall rail 2 1/4" above finish ceiling line (See detail A & B) to reinforced wall with screws (provide by others). Field trim last rail in row.

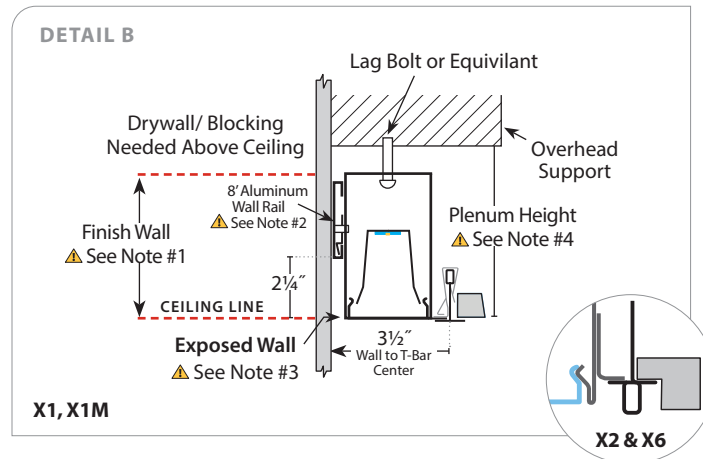
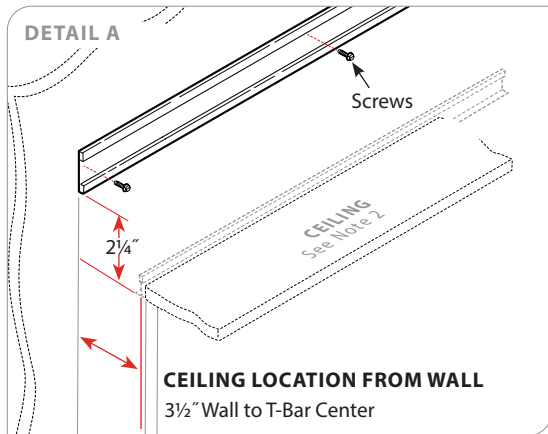

**WARNING:** Ground fixture in accordance with local and national electrical codes. Failure to do so may result in serious personal injury.



# P23 | Cove & Perimeter

## 2" Perimeter

### INSTALLATION INSTRUCTIONS



PRUDENTIAL LTG.

PRULITE.COM 213.746.0360

## SHALLOW PLENUM

### FIXTURE MOUNTING

1. To remove reflector assembly and expose mounting obrounds and driver wire leads, insert reflector removal tool and pull out at each end of reflector so spring clips (4) disengage from clip support bracket (see page 3).
2. Install finish plate with (2) #8 x 1/4" screws. (see detail C).
3. Lift fixture assembly and secure onto mounting rail (See detail D), secure fixture to structure with lag bolt. See cross sections (page 5, detail B). (Bolt and screws not provided).
4. Repeat #1, 2 and 3 to install remaining fixtures and corners in row. Secure fixtures end to end with (2) body joiner, (2) #8 x 1/4" screws per seam and (2) aligner pins. (See joining detail, page 4).

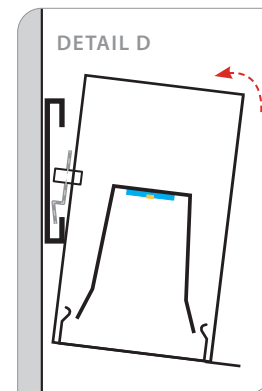
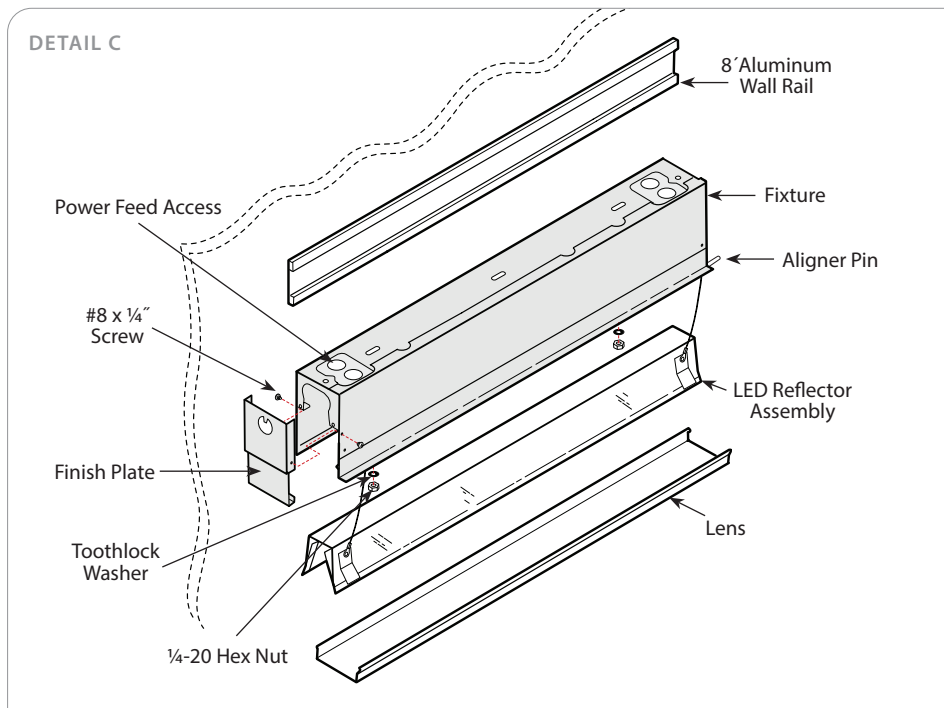

**WARNING:** Ground fixture in accordance with local and national electrical codes. Failure to do so may result in serious personal injury.



# P23 | Cove & Perimeter 2" Perimeter

## INSTALLATION INSTRUCTIONS



PRUDENTIAL LTG.

PRULITE.COM 213.746.0360

### FILLER KIT

#### TOOLS REQUIRED

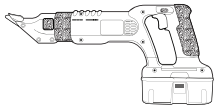

Power Shears

or

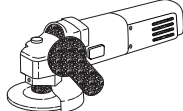

Grinder



Drill

### INSTALLATION

**PLEASE READ THE FOLLOWING INSTRUCTIONS CAREFULLY:**

1. Determine **FILLER** location & measure length of filler needed.

#### WALL TO WALL

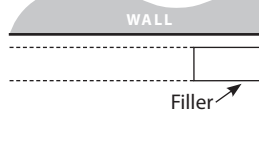

Measure from last fixture to wall (Subtract 1/4")

#### LIGHT POCKET

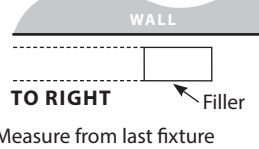

Measure from last fixture to ceiling opening (Subtract 5/16" for X3/X7)

#### PATTERN

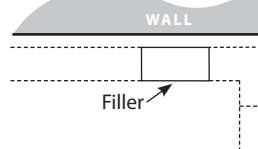

Measure from last fixture to connector

#### FLUSH

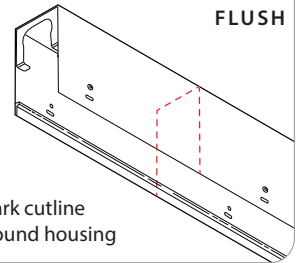

Mark cutline around housing

2. Disassemble **FILLER** Kit.

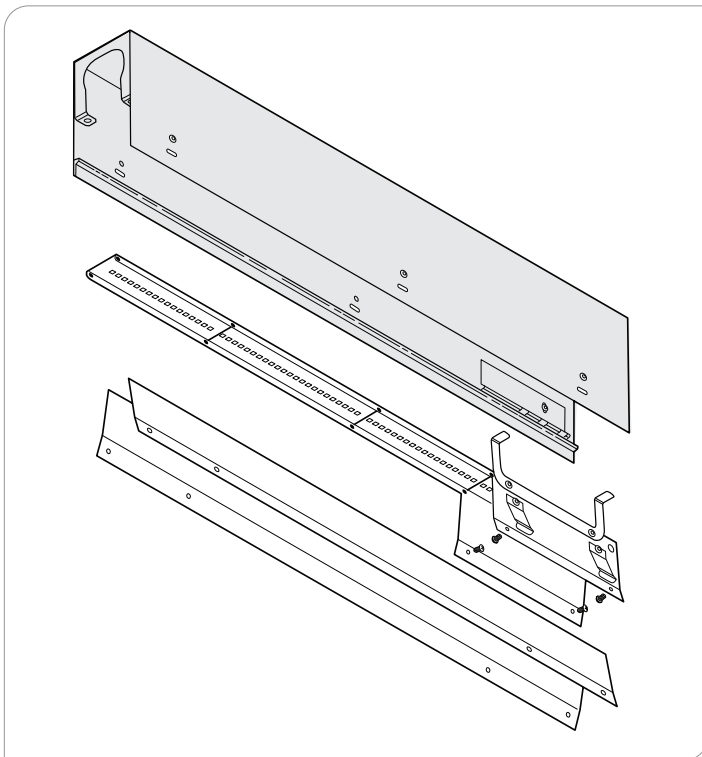

3. Measure Trim and Mark for Cutting

#### WALL TO WALL & PATTERN

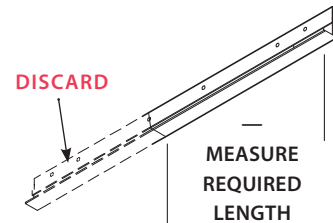

#### LIGHT POCKET

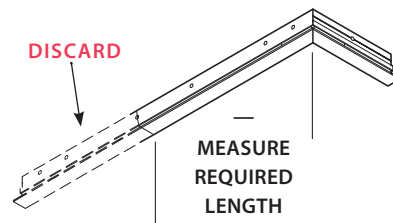

**WARNING:** Ground fixture in accordance with local and national electrical codes. Failure to do so may result in serious personal injury.



Prudential Ltg. reserves the right to change design specifications or materials without notice. Please visit [prulite.com](http://prulite.com) for most current data.  
© 2015 All rights reserved - All products manufactured at: Prudential Ltg. 1774 E. 21st Street, Los Angeles, CA 90058



# P23 | Cove & Perimeter

## 2" Perimeter

### INSTALLATION INSTRUCTIONS



PRUDENTIAL LTG.

PRULITE.COM 213.746.0360

### FILLER KIT

4. Cut and discard Filler Housing.

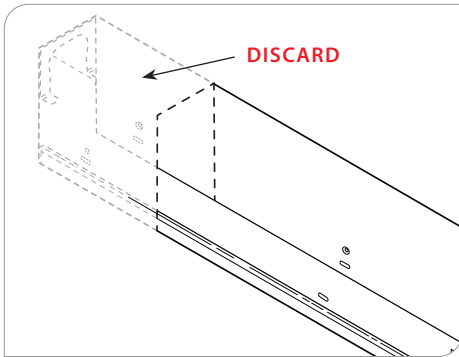

5. Cut and discard reflector.

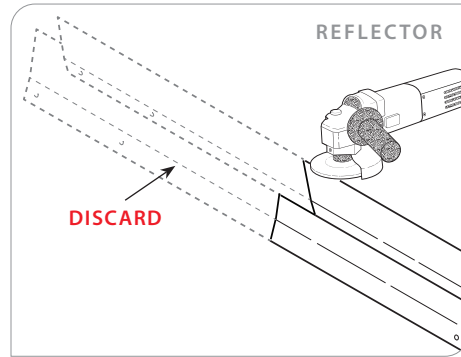

6. Drill and attach end plate.

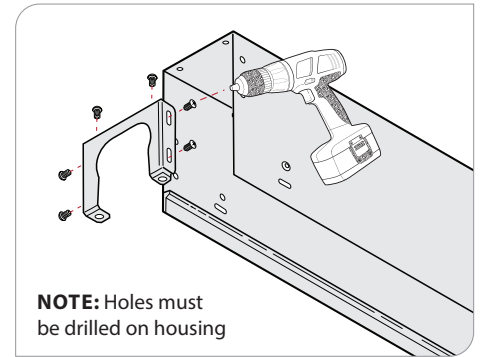

7. Join housings.

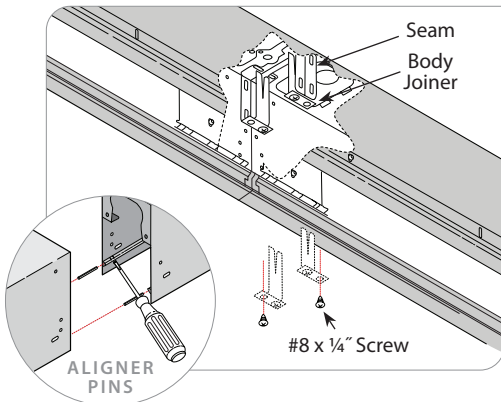

8. Install filler.

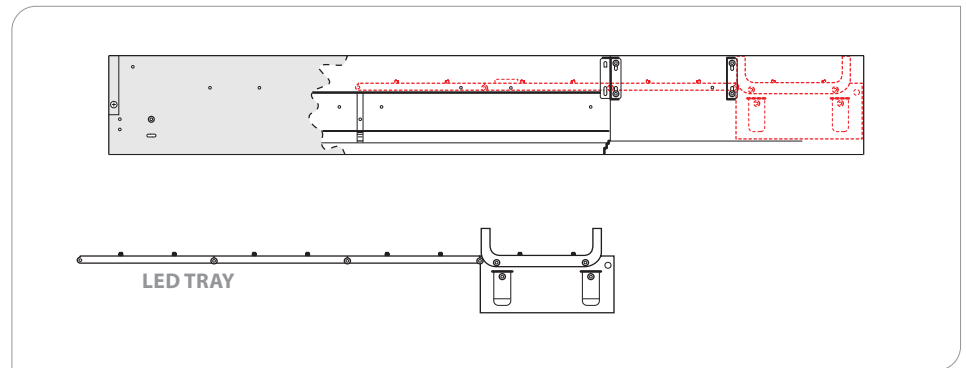

**NOTE:** Do not cut or remove any section of LED tray as it will cause uneven lights levels in the filler kit. All sections of the LED tray should be rolled under the led reflector in the previous fixture housing.

9. Install Reflectors.

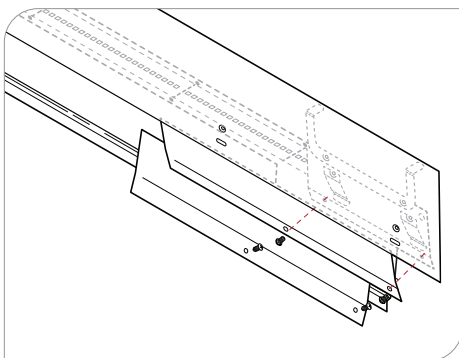

**WARNING:** Ground fixture in accordance with local and national electrical codes. Failure to do so may result in serious personal injury.