



Stream™ | Perimeter

4" Perimeter

INSTALLATION INSTRUCTIONS

X7W: T-BAR (X1, X1M, X2, X6)



PRUDENTIAL LTG.

PRULITE.COM 213.746.0360

PARTS LIST	PART NO.	DESCRIPTION
	100638	Overhead Mounting Bracket (OMB)
	100-00090-02	Wall Rail
	VARIES (SEE PRUDENTIAL LAYOUT)	Plaster Trim Flange
	74650	Aligner Spline
	100-00126-14	1/4" Fender Washer
	100-00179-14	8-32 U-Nut
	100-00039-14	8-32 x 2" Machine Bolt
	100-00125-14	#8 x 3/8" Sheet Metal Screw
	39837	T-Bar Clip
	100-00047-20	Round Base Magnet
	100010	Finished End Plate
	—	Latex Gloves

WARNING: Ground fixture in according with local and national electrical codes. Failure to do so may result in serious personal injury.



Prudential Ltg. reserves the right to change design specifications or materials without notice. Please visit prulite.com for most current data.
© 2015 All rights reserved – All products manufactured at: Prudential Ltg. 1774 E. 21st Street, Los Angeles, CA 90058



Stream™ | Perimeter

4" Perimeter

INSTALLATION INSTRUCTIONS

X7W: T-BAR (X1, X1M, X2, X6)



PRUDENTIAL LTG.

PRULITE.COM 213.746.0360

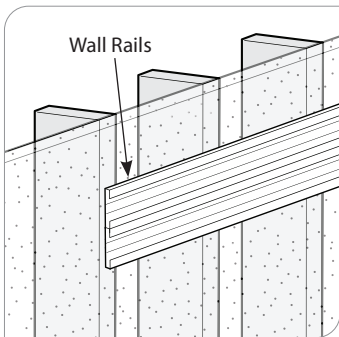
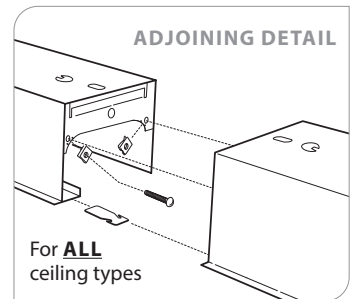
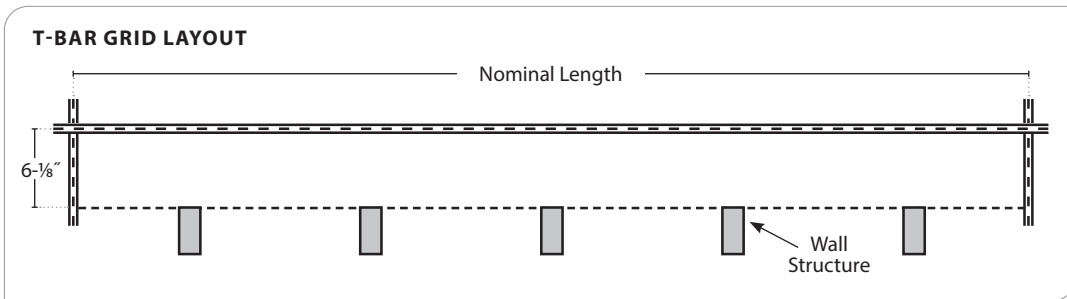
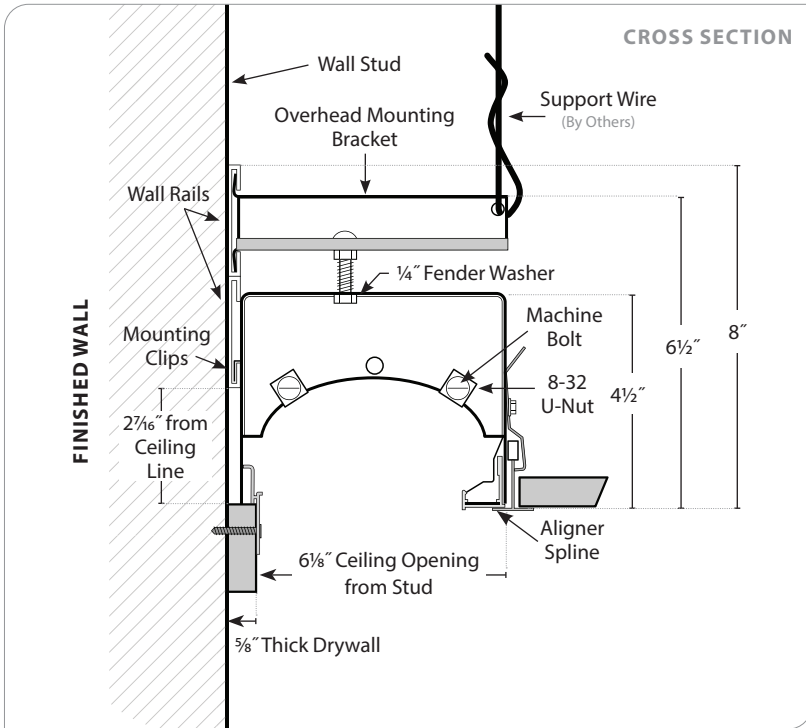

1. Mount wall rails directly to wall structure. See cross section for recommended height.

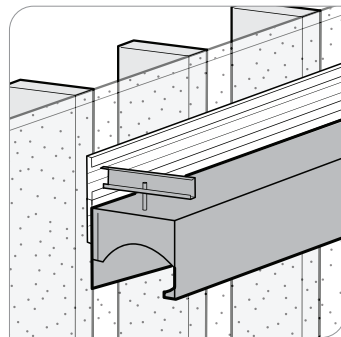

2. Mount fixture to rails using mounting clips and overhead mounting brackets.

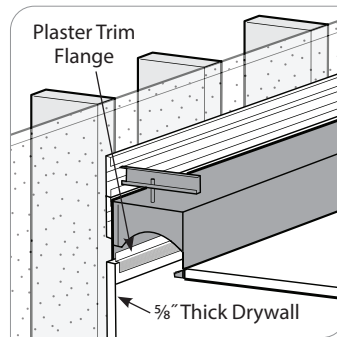

3. Mount 5/8" thick drywall flush to bottom edge of fixture housing. Attach plaster trim flange along top of drywall and fasten with drywall screws (by others). May have to trim flange to fit.

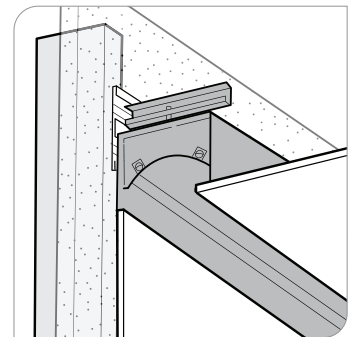

4. Tape and plaster over trim flange.

WARNING: Ground fixture in according with local and national electrical codes. Failure to do so may result in serious personal injury.



Prudential Ltg. reserves the right to change design specifications or materials without notice. Please visit prulite.com for most current data.
© 2015 All rights reserved – All products manufactured at: Prudential Ltg. 1774 E. 21st Street, Los Angeles, CA 90058



Stream™ | Perimeter Corners

INSTALLATION INSTRUCTIONS

X7W: T-BAR (X1, X1M, X2, X6)



PRUDENTIAL LTG.

PRULITE.COM 213.746.0360

PARTS LIST	PART NO.	DESCRIPTION
	100638	Overhead Mounting Bracket (OMB)
	74650	Aligner Spline
	100-00126-14	1/4" Fender Washer
	100-00179-14	8-32 U-Nut
	100-00039-14	8-32 x 2" Machine Bolt
	39837	T-Bar Clip
	100-00125-14	#8 x 3/8" Sheet Metal Screw

T-Bar Ceilings: Corner T-Bar length is 1' nominal.

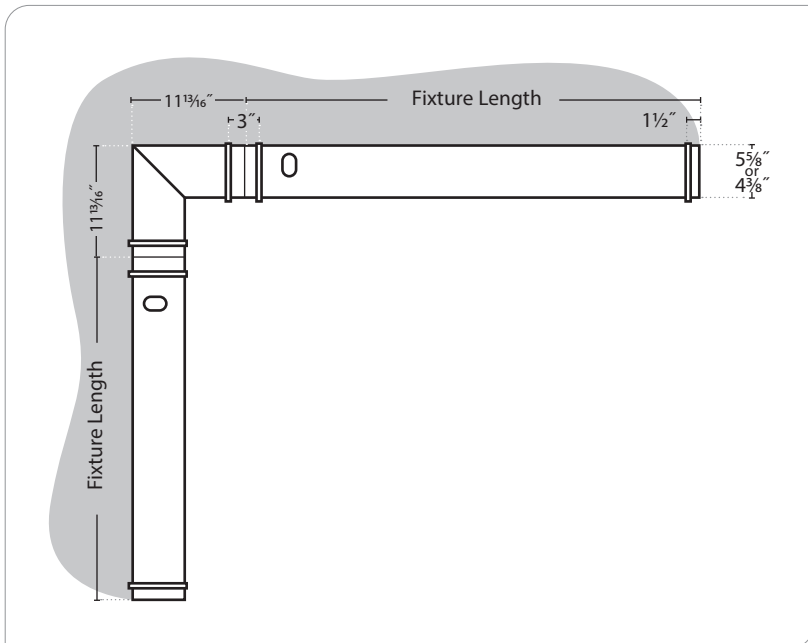

WARNING: Ground fixture in according with local and national electrical codes. Failure to do so may result in serious personal injury.



Prudential Ltg. reserves the right to change design specifications or materials without notice. Please visit prulite.com for most current data.
© 2015 All rights reserved - All products manufactured at: Prudential Ltg. 1774 E. 21st Street, Los Angeles, CA 90058



CORNER INSTALLATION STEPS

NOTE: Corners are powered by driver in previous fixture.

DO NOT remove foam inserts until step 3.

1. Remove wire covers from corners to reveal mounting slots. Install corner body into ceiling.
2. Remove driver covers from adjoining fixtures. Join fixtures to corner with (2) #8-32 x 2" machine bolts, (2) u-nuts, and (2) aligner splines at each joint. Reinstall all wire and driver covers.
3. Remove foam inserts from corners (molded reflector cannot be removed).
4. Wearing gloves, install long film in both adjoining rows (runs into corner fixture with 3/8" overlap).

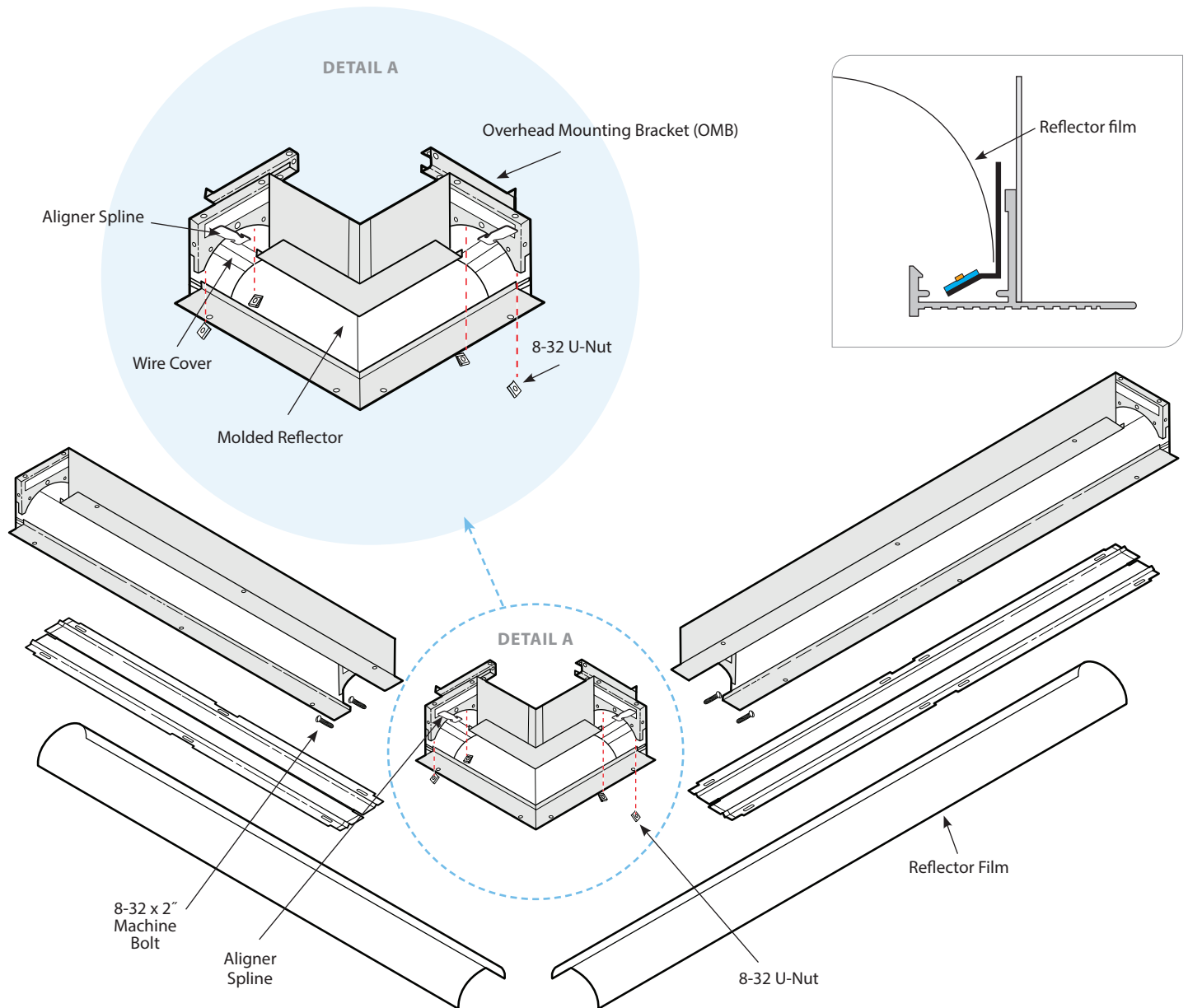

WARNING: Ground fixture in according with local and national electrical codes. Failure to do so may result in serious personal injury.



X7W: T-BAR (X1, X1M, X2, X6)

- See row diagram or Prudential Lighting plan layout (if provided). Begin all row mounting from left to right (see arrows).
- Depending upon ceiling or wall construction reinforcement may be required at mounting locations.
- Continuous row: Install one fixture section at a time.
- Filler length 12" min/ 24" max.
- Filler may have internal driver, or powered by other fixture. See layout drawing for details.

GENERAL INSTALLATION

1. Determine filler location and measure length of filler needed. Mark cut line around housing (Discard side as indicated in figure 1).
2. Remove driver cover. Remove outside screws on one side to separate filler into halves lengthwise.

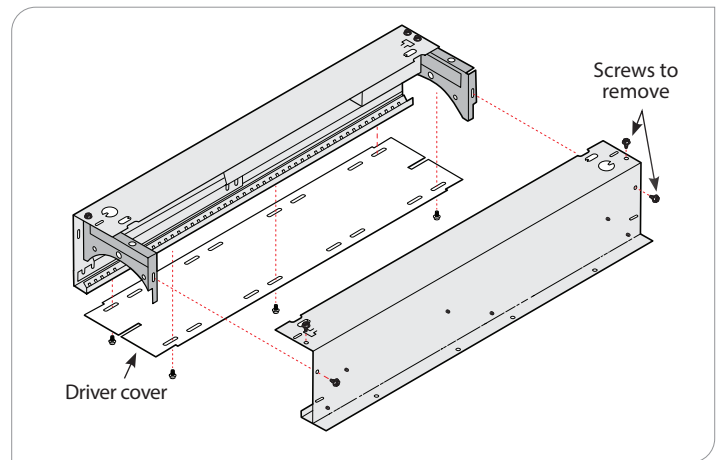
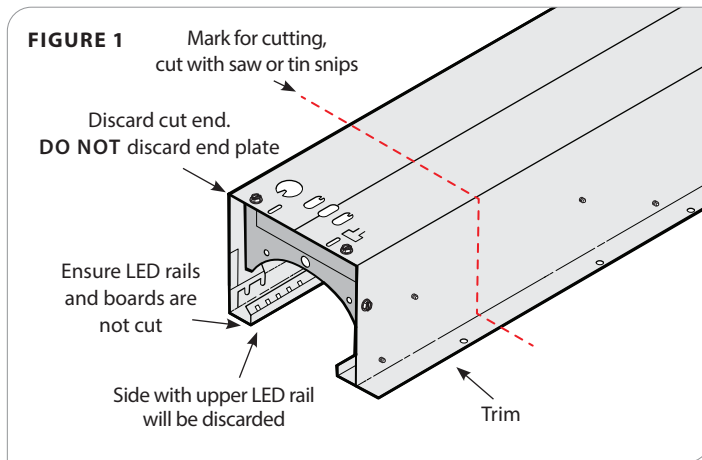

3. Remove end plate and driver cover support tabs from filler bodies.
4. Remove upper LED rails from filler bodies (May require loosening electrical connectors)
5. Cut filler bodies, trims and driver cover to required length and discard unneeded ends. (See Figure 1).
6. Align upper LED rails to cut end of filler and drill holes for #6 screws as required to install upper LED rails and end plates. LED boards will overlap.
7. Rewire LED boards and reassemble filler by reversing steps 2-4.

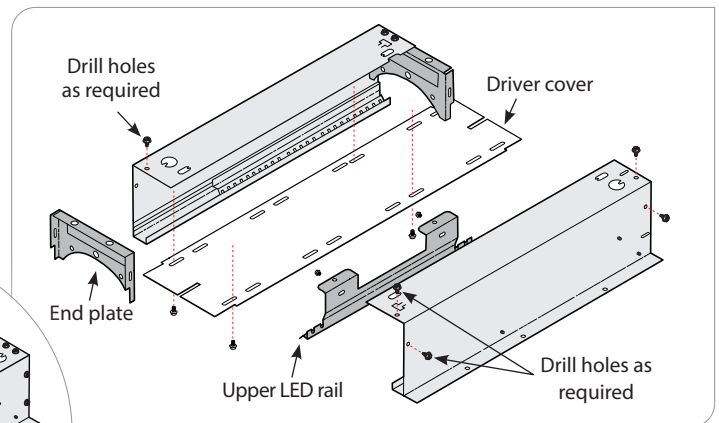
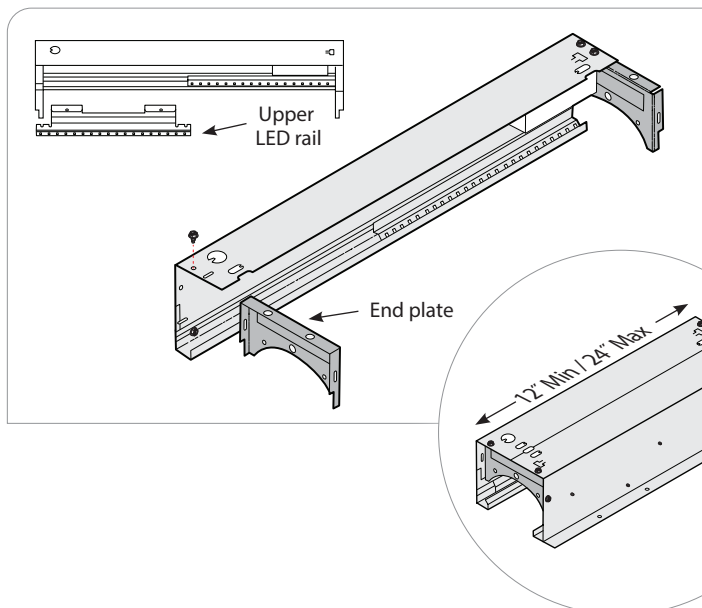

WARNING: Ground fixture in according with local and national electrical codes. Failure to do so may result in serious personal injury.





Stream™ | Perimeter Reflector Installation

MAINTENANCE INSTRUCTIONS

X7W: T-BAR (X1, X1M, X2, X6)



PRUDENTIAL LTG.

PRULITE.COM 213.746.0360



REFLECTOR
INSTALLATION
VIDEO

PARTS LIST	PART NO.	DESCRIPTION
------------	----------	-------------



100010

Finished End Plate

PARTS LIST	PART NO.	DESCRIPTION
------------	----------	-------------

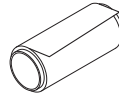

—

Reflector



—

Latex Gloves



100-00047-20

Round Base Magnet

PLEASE READ THE FOLLOWING INSTRUCTIONS CAREFULLY:

Test LEDs and confirm they are all lit before beginning Reflector install.

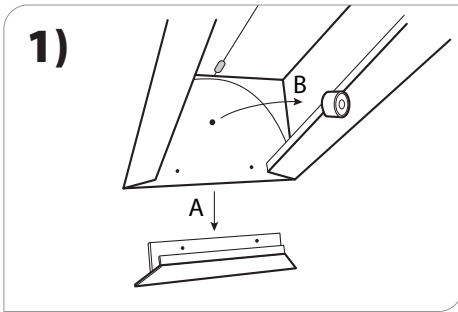

Remove trim (A) and magnet (B) from one end (**DO NOT** remove A from X7 ceilings).

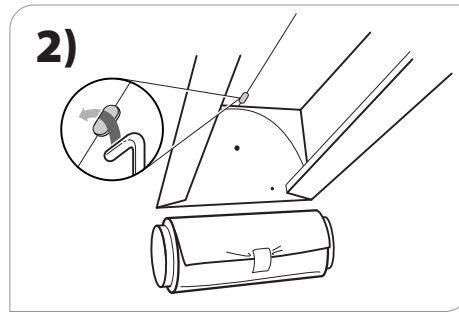

Matte side of film will face down towards room when installed.

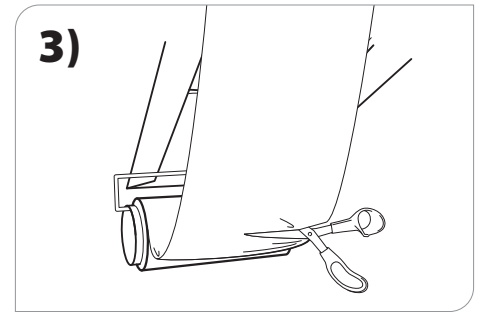

Cut reflector to fit — from side with excess reflector. **DO NOT UNDER-CUT.** Make small cuts until reflector fits into housing, covering curved end plate.

For each corners: Reflector should go into corner housing 3/8" and overlap corner reflector ~1/4"

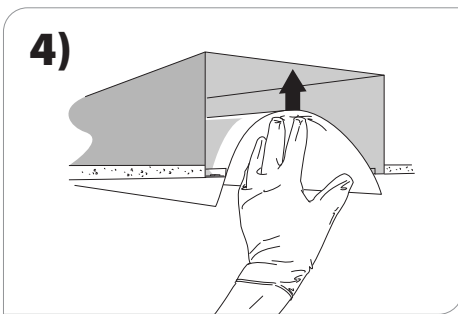

Push reflector into housing to proper position. Make sure no LED emitters are covered. Wire leads may need to be tucked away from emitters and reflector.

IF INSTALLATION IS LONGER THAN 6', REFLECTORS WILL BE PROVIDED IN SECTIONS AND WILL OVERLAP EACH OTHER TO AVOID VISIBLE SEAMS.

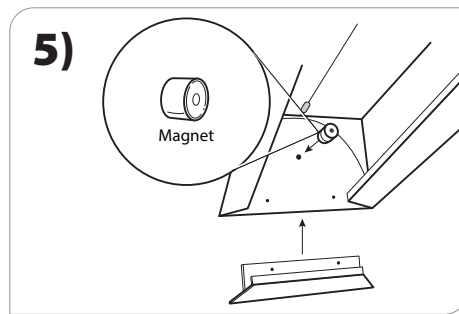

Reinstall magnet and trim.

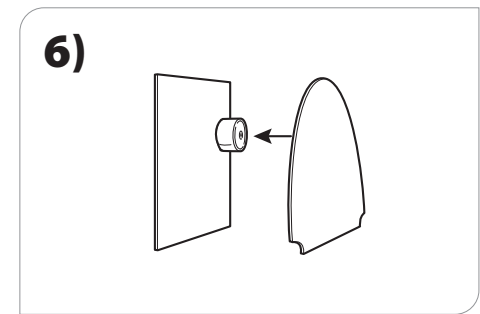

Install finish end plate to magnets on each end of row. Adjust end plate as needed to close gaps along reflector.

CLEANING INSTRUCTIONS:

Reflector film may be cleaned as needed. To avoid contaminating LED emitters, use only water and/or isopropyl alcohol solution on a clean wash cloth. Other cleaning chemicals could damage LED emitters.

WARNING: Ground fixture in according with local and national electrical codes. Failure to do so may result in serious personal injury.



Prudential Ltg. reserves the right to change design specifications or materials without notice. Please visit prulite.com for most current data. © 2015 All rights reserved – All products manufactured at: Prudential Ltg. 1774 E. 21st Street, Los Angeles, CA 90058



Stream™ | Perimeter LED & Driver Replacement

MAINTENANCE INSTRUCTIONS

X7W: T-BAR (X1, X1M, X2, X6)



PRUDENTIAL LTG.

PRULITE.COM 213.746.0360

PARTS LIST	PART NO.	DESCRIPTION
	100010	Finished End Plate
	—	Latex Gloves

PLEASE READ THE FOLLOWING INSTRUCTIONS CAREFULLY:

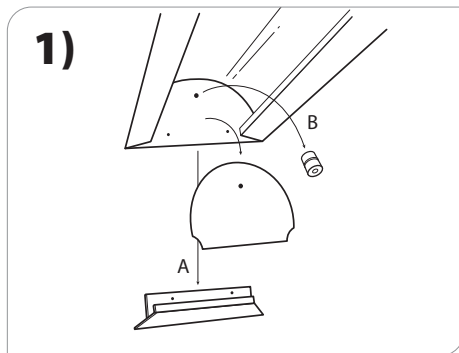

1) Remove end plate, magnet and end trim (when possible).

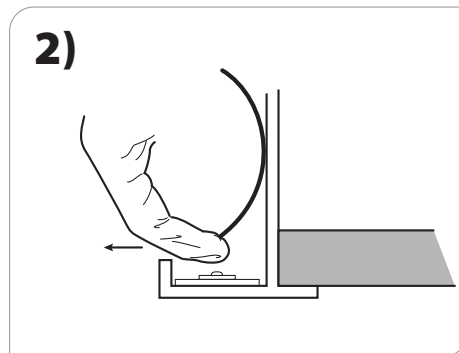

2) Use gloves provided. Gently lift bottom edge of reflector and remove from housing.

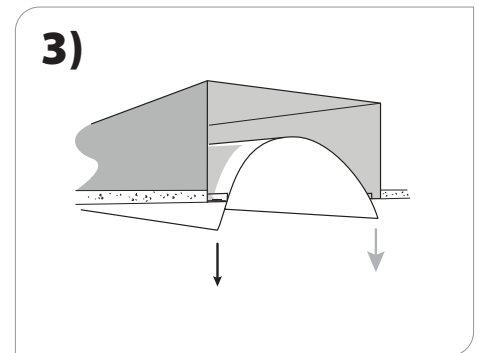

3) **USE GLOVES PROVIDED.** Pull reflector over entirety of housing row. Tighten roll to remove excess slack. Clamp roll to keep from unrolling.

4) Remove sheet metal cover held on by screws to access wiring. Replace faulty equipment and reinstall all components in reverse order.

WARNING: Ground fixture in according with local and national electrical codes. Failure to do so may result in serious personal injury.



Prudential Ltg. reserves the right to change design specifications or materials without notice. Please visit prulite.com for most current data.
© 2015 All rights reserved – All products manufactured at: Prudential Ltg. 1774 E. 21st Street, Los Angeles, CA 90058