

P3630 MONO-2 POINT X3B MOUNTING INSTALLATION INSTRUCTIONS

WARNING:

GROUND FIXTURE IN ACCORDANCE WITH LOCAL AND NATIONAL ELECTRICAL CODES. FAILURE TO DO SO MAY RESULT IN SERIOUS PERSONAL INJURY.

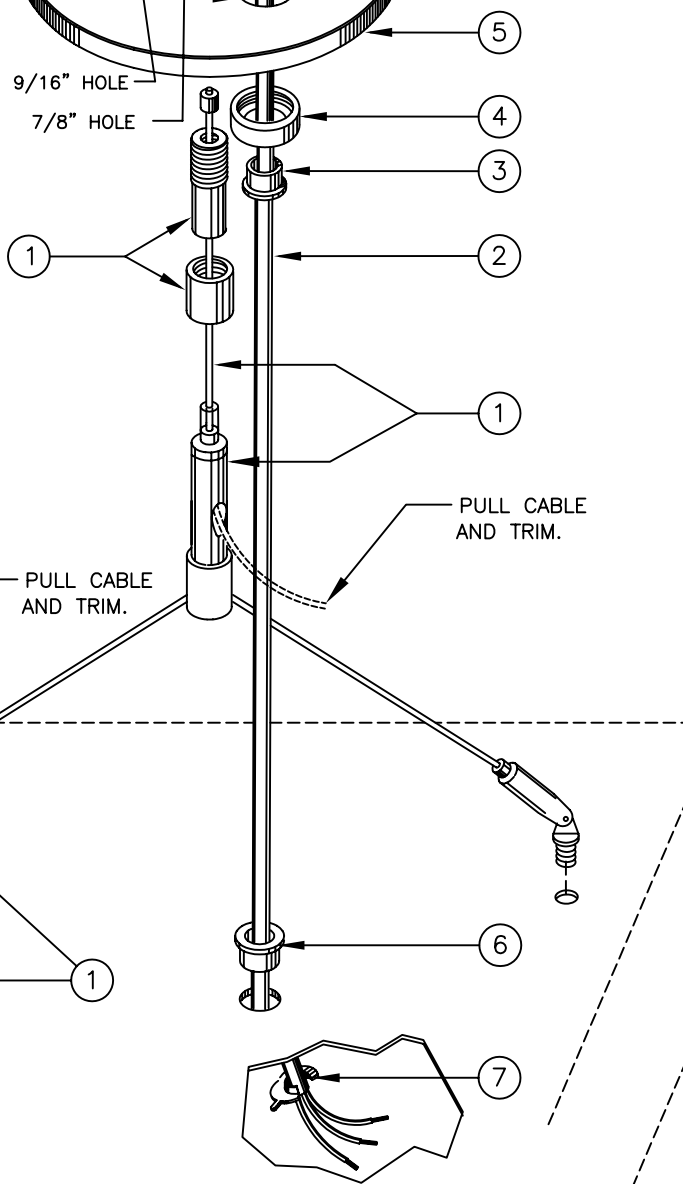
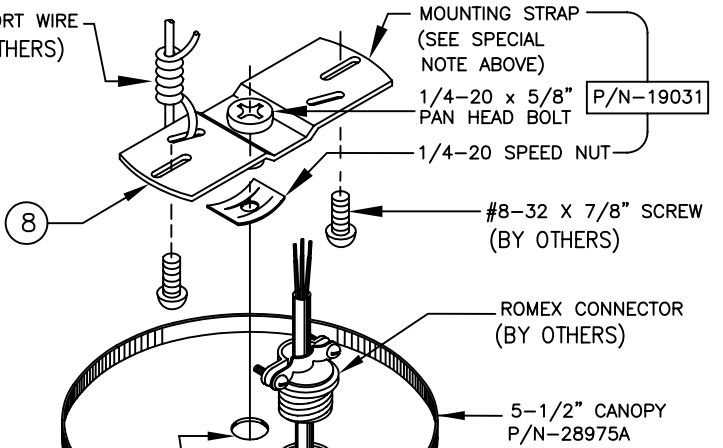
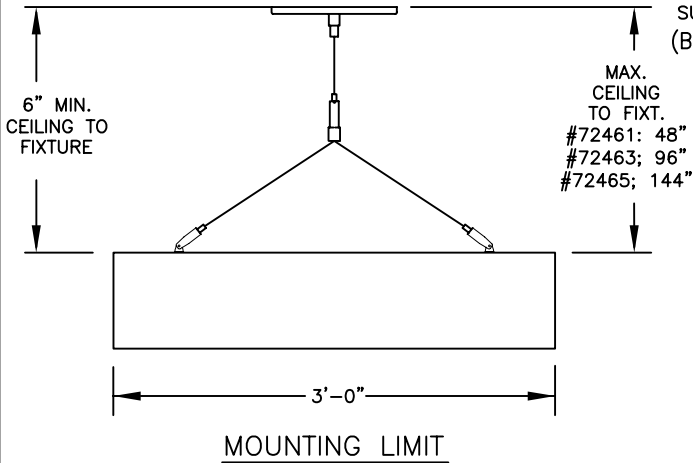

ASSEMBLY NUMBER 72461 (48" CABLE) (2 PER FIXT.)			
SYM.	P/N	PART DESCRIPTION	QTY.
8	19031	MOUNTING STRAP, 1/4-20 SPEED NUT, 1/4-20 X 5/8" PAN HD. SCREW	1
7	53243	METAL STRAIN RELIEF BUSHING	1
6	53345	WHITE SNAP BUSHING	1
5	28975A	5-1/2" DIA. WHITE CANOPY	1
4	53359	THREADED BUSHING	1
3	53360	WHITE UNIVERSAL BUSHING	1
2	53263	18 GA. 3 WIRE SJT CORD 6'	1
1	72448	COUPLER W/ 53" CABLE	1
		3 WAY CABLE ADAPTER	1
		1/4-20 KEPS LOCK NUT	2
		PIVOTING CABLE GLIDER	2

ASSEMBLY NUMBER 72463 (96" CABLE) (2 PER FIXT.)			
SYM.	P/N	PART DESCRIPTION	QTY.
8	19031	MOUNTING STRAP, 1/4-20 SPEED NUT, 1/4-20 X 5/8" PAN HD. SCREW	1
7	53243	METAL STRAIN RELIEF BUSHING	1
6	53345	WHITE SNAP BUSHING	1
5	28975A	5-1/2" DIA. WHITE CANOPY	1
4	53359	THREADED BUSHING	1
3	53360	WHITE UNIVERSAL BUSHING	1
2	43039	18 GA. 3 WIRE SJT CORD 10'	1
1	45487	COUPLER W/ 96" CABLE	1
		3 WAY CABLE ADAPTER	1
		1/4-20 KEPS LOCK NUT	2
		PIVOTING CABLE GLIDER	2

ASSEMBLY NUMBER 72465 (144" CABLE) (2 PER FIXT.)			
SYM.	P/N	PART DESCRIPTION	QTY.
8	19031	MOUNTING STRAP, 1/4-20 SPEED NUT, 1/4-20 X 5/8" PAN HD. SCREW	1
7	53243	METAL STRAIN RELIEF BUSHING	1
6	53345	WHITE SNAP BUSHING	1
5	28975A	5-1/2" DIA. WHITE CANOPY	1
4	53359	THREADED BUSHING	1
3	53360	WHITE UNIVERSAL BUSHING	1
2	43056	18 GA. 3 WIRE SJT CORD 14'	1
1	72449	COUPLER W/ 144" CABLE	1
		3 WAY CABLE ADAPTER	1
		1/4-20 KEPS LOCK NUT	2
		PIVOTING CABLE GLIDER	2



1774 EAST 21ST STREET L.A. CA 90058
TEL. (213)746-0360 FAX (213)746-8838
PRUDENTIAL LTG. WWW.PRULITE.COM

DRAWN BY: CK	DATE 11/17/10
CHK.	DATE

DWG. No.	72461
	72463
	72465

DISK No.	
REV.	